

Service Manual

Cordless Drill & Driver

Model No. EY7411

EUROPE

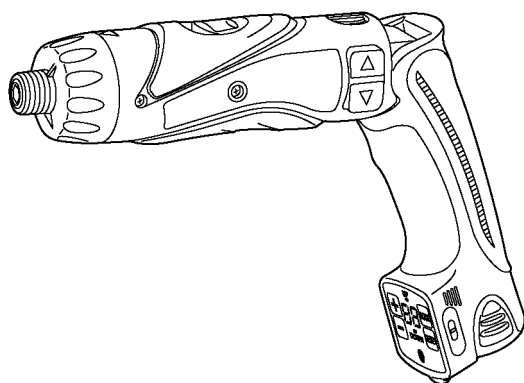

⚠ WARNING

This service information is designed for experienced repair technicians only and is not designed for use by the general public. It does not contain warnings or cautions to advise non-technical individuals of potential dangers in attempting to service a product. Products powered by electricity should be serviced or repaired only by experienced professional technicians. Any attempt to service or repair the product or products dealt with in this service information by anyone else could result in serious injury or death.

IMPORTANT SAFETY NOTICE

There are special components used in this equipment which are important for safety. These parts are marked by ⚠ in the Schematic Diagrams, Circuit Board Diagrams, Exploded Views and Replacement Parts List. It is essential that these critical parts should be replaced with manufacturer's specified parts to prevent shock, fire or other hazards. Do not modify the original design without permission of manufacturer.

TABLE OF CONTENTS

	PAGE	PAGE
1 Warning-----	2	
2 Specifications -----	2	
3 Troubleshooting Guide-----	3	
4 Disassembly and Assembly Instructions -----	6	
5 Wiring Connection Diagram -----	9	
6 Schematic Diagram-----	9	
7 Exploded View and Replacement Parts List -----	10	

Panasonic

© 2007 Matsushita Electric Works, Ltd.
All rights reserved. Unauthorized copying and distribution is a violation of law.

1 Warning

Caution:

- Pb free solder has a higher melting point than standard solder; Typically the melting point is 50 - 70°F (30 - 40°C) higher. Please use a soldering iron with temperature control and adjust it to 750 ± 20°F (400 ± 10°C). In case of using high temperature soldering iron, please be careful not to heat too long.
- Pb free solder will tend to splash when heated too high (about 1100°F / 600°C).

2 Specifications

MAIN UNIT

Capacity	Screw driving	Machine Screw	M2.5 - M5
		Wood screw	φ 3.8 X 38 mm (5/32" X 1-29/64")
	Drilling	For metal	φ 5 mm (13/64") spc t=1.6mm
Motor			3.6V DC
No load speed	LOW	200 min ⁻¹ (rpm)	
	HIGH	600 min ⁻¹ (rpm)	
Maximum clutch torque			3.0 Nm (30 kgf-cm, 26 in-lbs)
Overall length			283 mm (11-5/32")
Weight (with battery pack)			0.5 kg (1.1 lbs)

3 Troubleshooting Guide

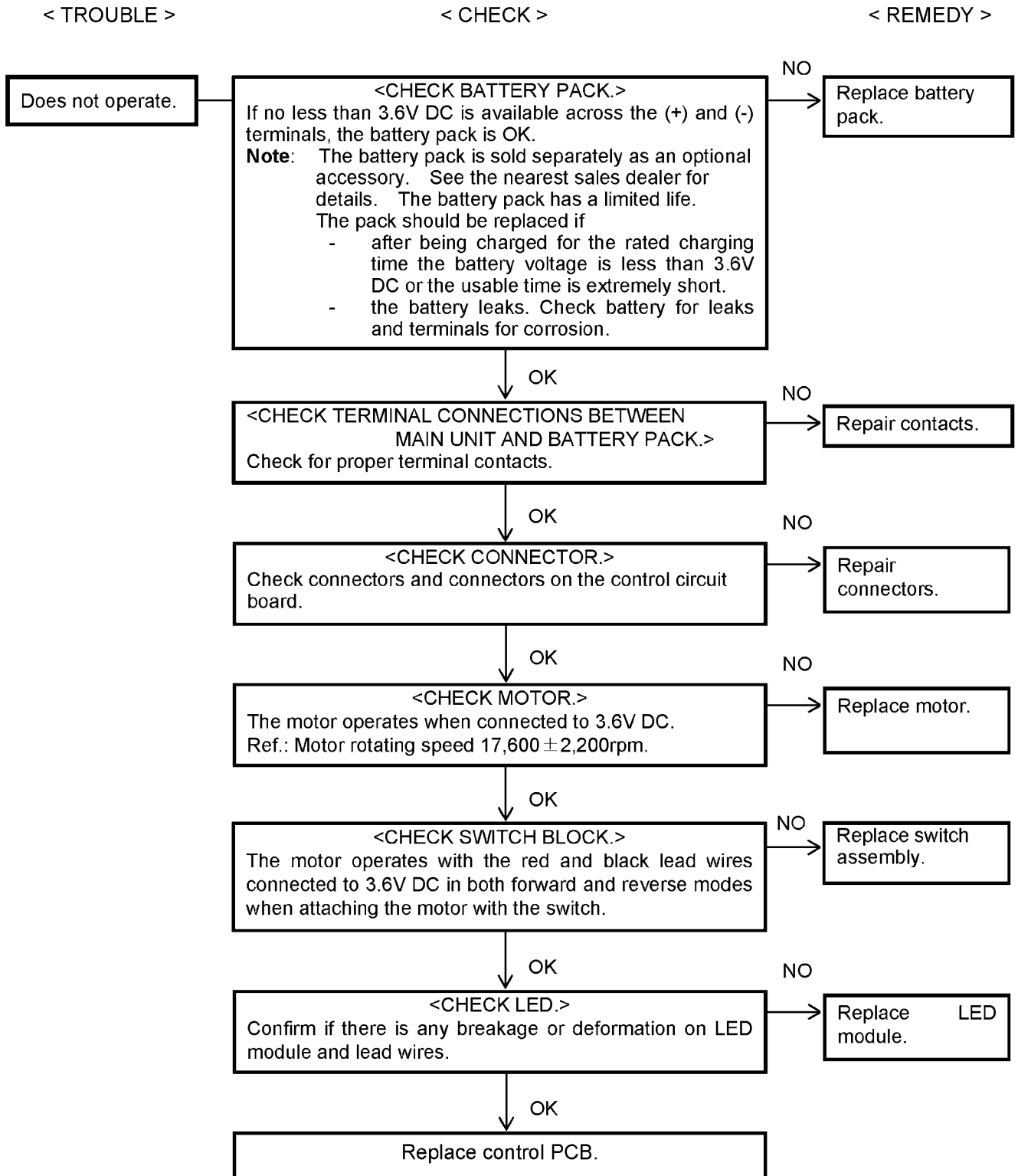

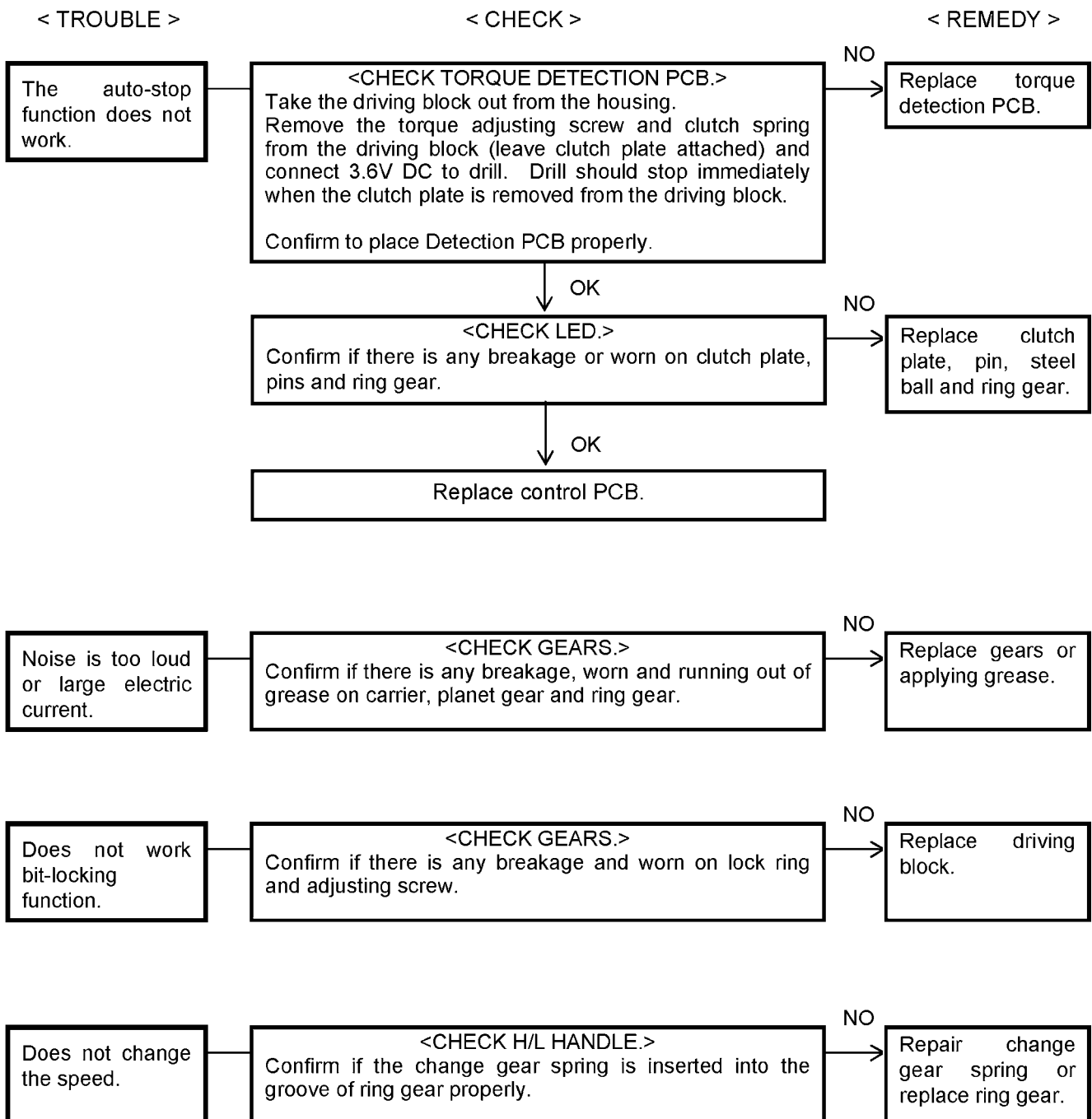

< TROUBLE >

< CHECK >

< REMEDY >

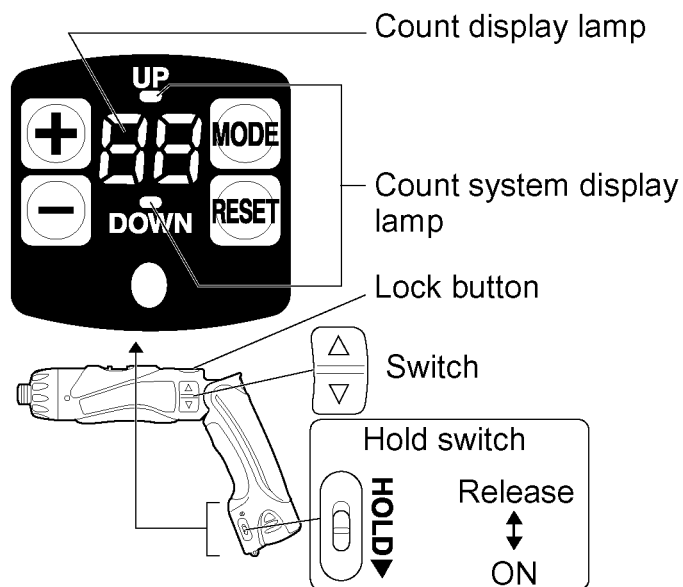
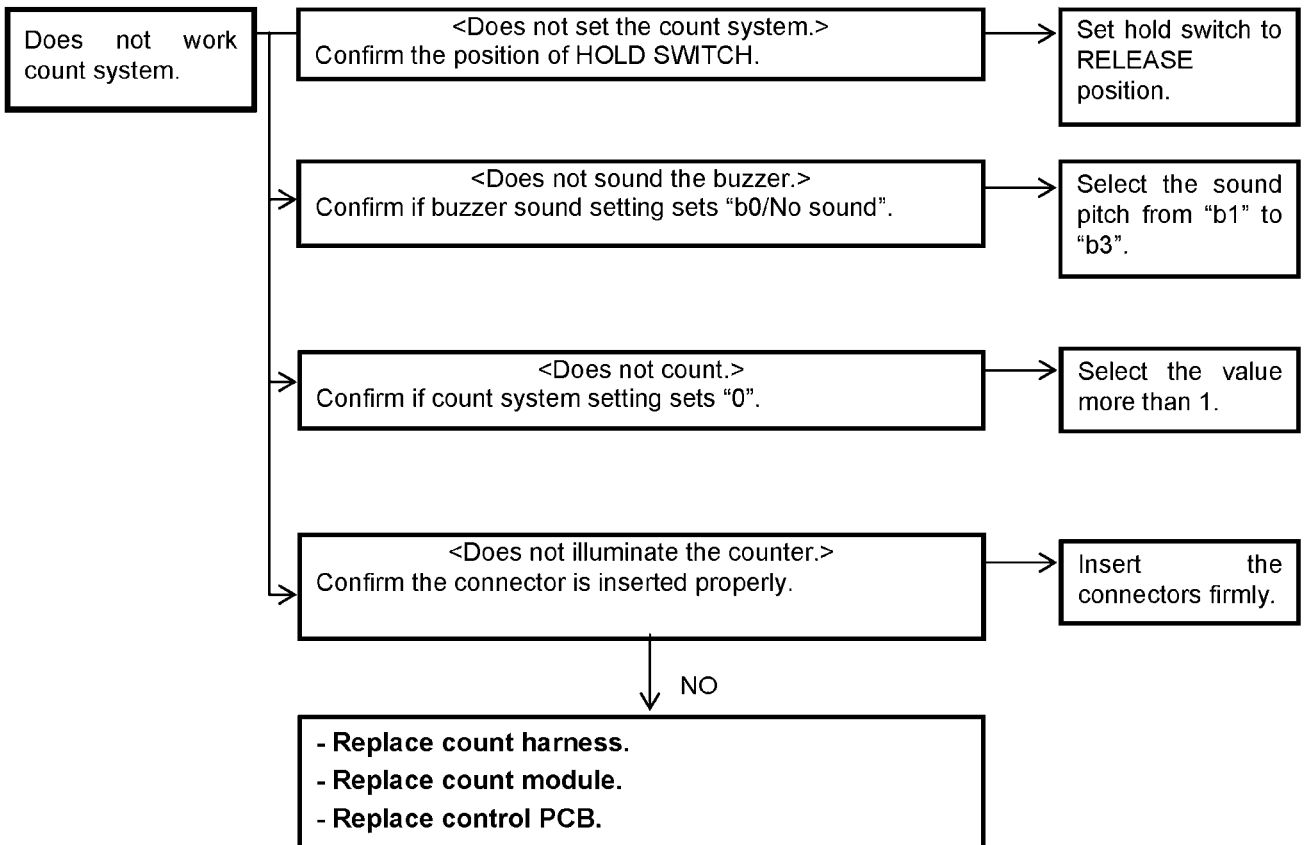

4 Disassembly and Assembly Instructions

4.1. Disassembly Instructions

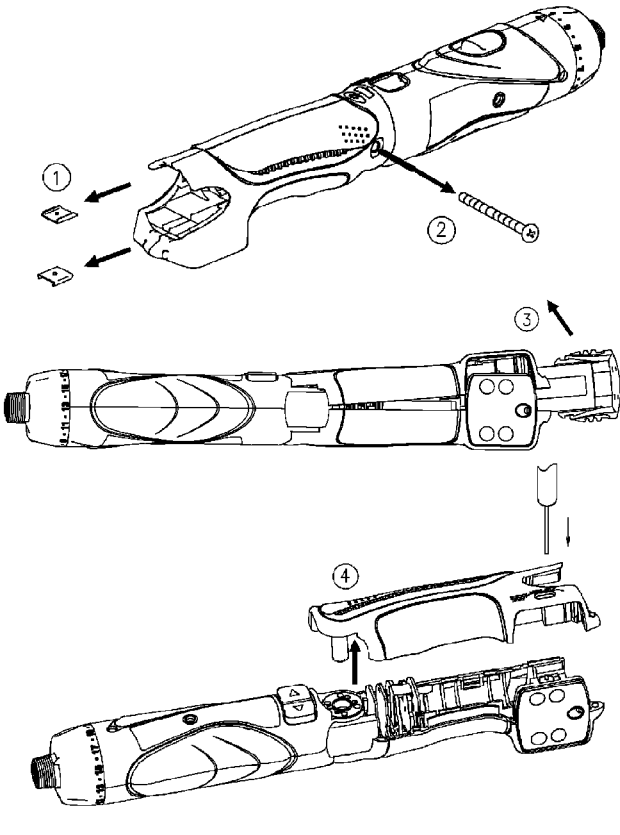
Ref. No. 1A	Procedure 1A	Removal of the grip.
		<ol style="list-style-type: none">1. Remove both sides of the grip fastening clip by sliding it outward.2. Remove one grip fastening screw.3. To separate the grip housing, insert the battery pack into the grip about one third. Slightly shake the battery until the end of grip will be opened.4. Separate the grip A and B with holding the control panel by something like a fine stick.

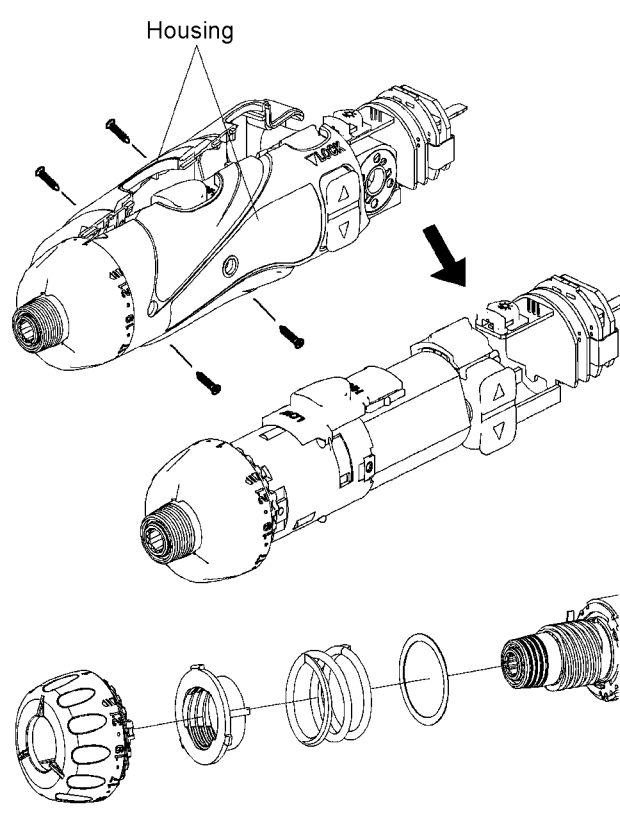
Ref. No. 1B	Procedure 1A → 1B	Removal of the housing.
		<ol style="list-style-type: none">1. Remove 4 screws from the housing.2. Separate the housing A and B.3. Remove the clutch handle, adjusting screw, clutch spring and clutch plate.

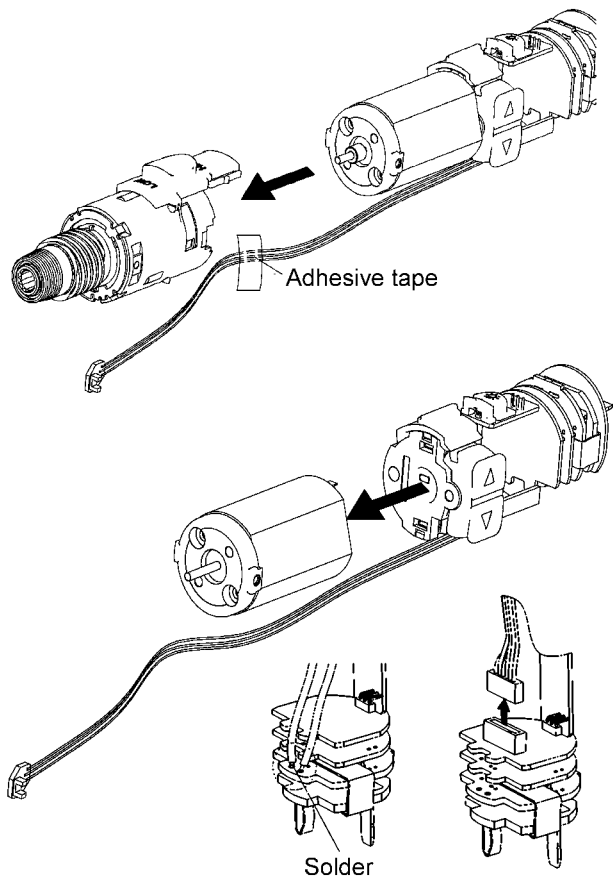
Ref. No. 1C	Procedure 1A → 1B → 1C	Removal of the motor.
		<ol style="list-style-type: none"> 1. Remove the motor and the switch block together with the torque detection PCB from the driving block. 2. Remove the switch from the motor.

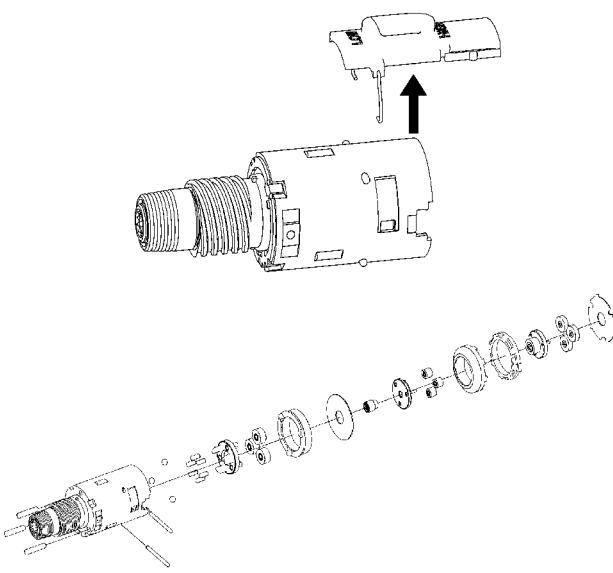
Ref. No. 1D	Procedure 1A → 1B → 1C → 1D	Removal of the driving block.
		<ol style="list-style-type: none"> 1. Remove High/Low handle by spreading the spring. 2. The internal parts of driving block can be disassembled.

4.2. Assembly Instructions

NOTE: When reassembling, apply grease around the ring and planet gears.

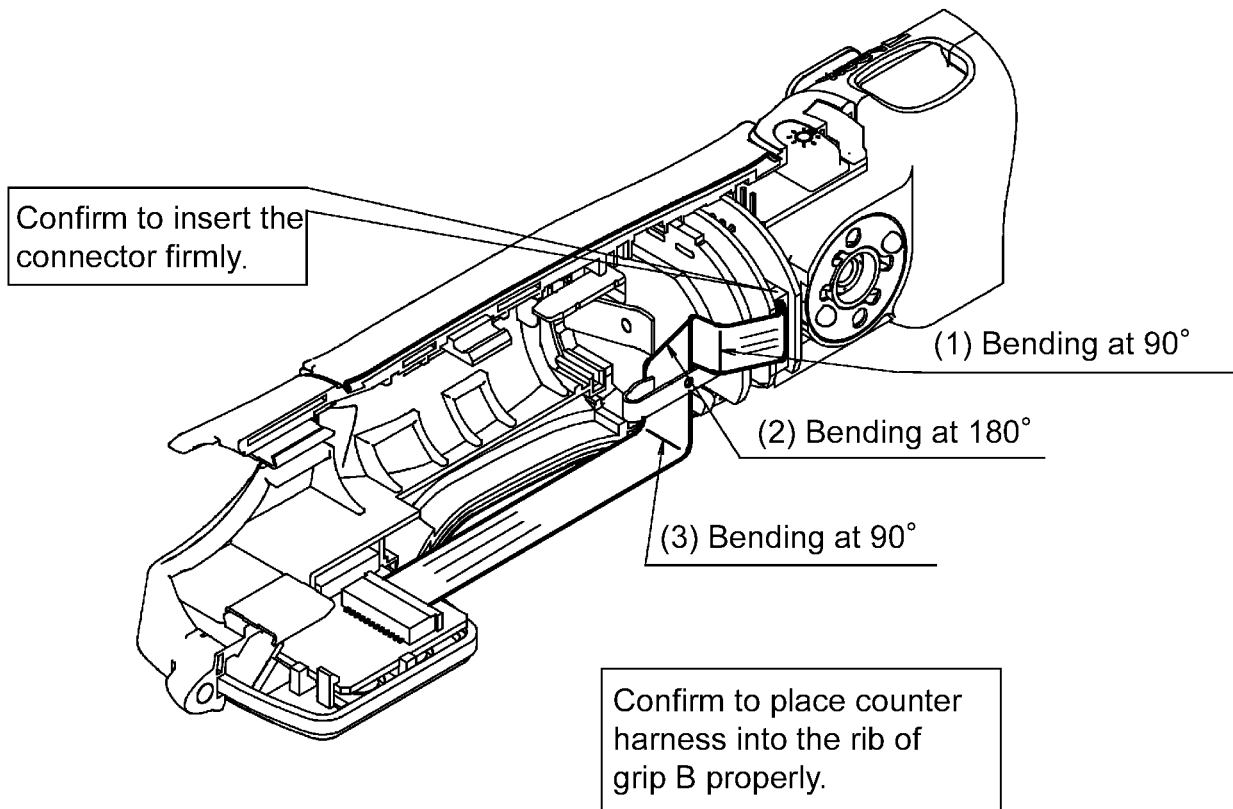

4.3. After Reassembling

Confirm the following points before returning the unit to a customer.

1. Motor rotation
HIGH: 600 ± 60 LOW: 200 ± 25
2. No load electric current
 $2.5 \pm 1.5A$
3. Confirm auto shut off function.
4. Confirm screw count function.
5. Confirm the direction of rotation on both Forward and Reverse side.
6. Confirm the attachment or removing the bit.
7. Confirm if there is no dirt, scratch, deformation, and clearance when inserting the battery pack.

5 Wiring Connection Diagram

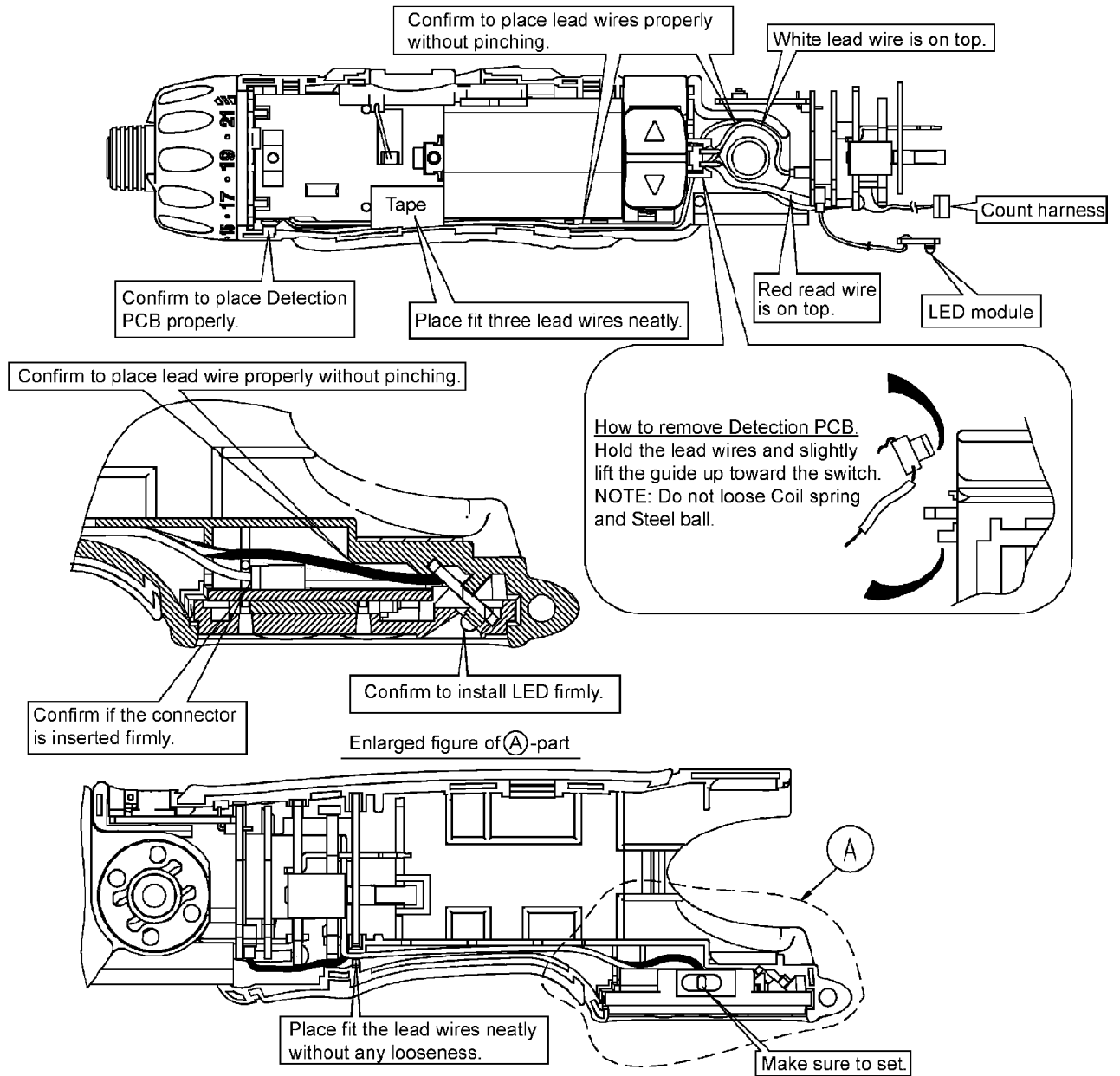

6 Schematic Diagram

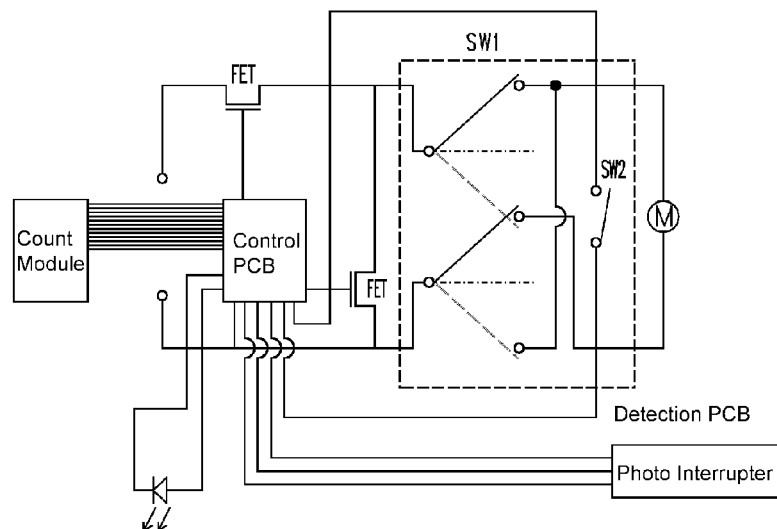

7 Exploded View and Replacement Parts List

7.1. Exploded View

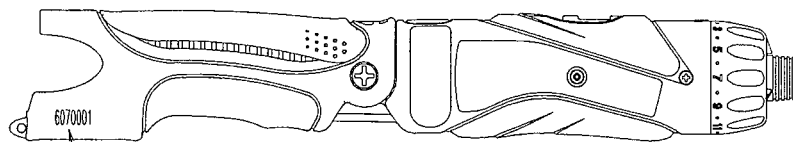
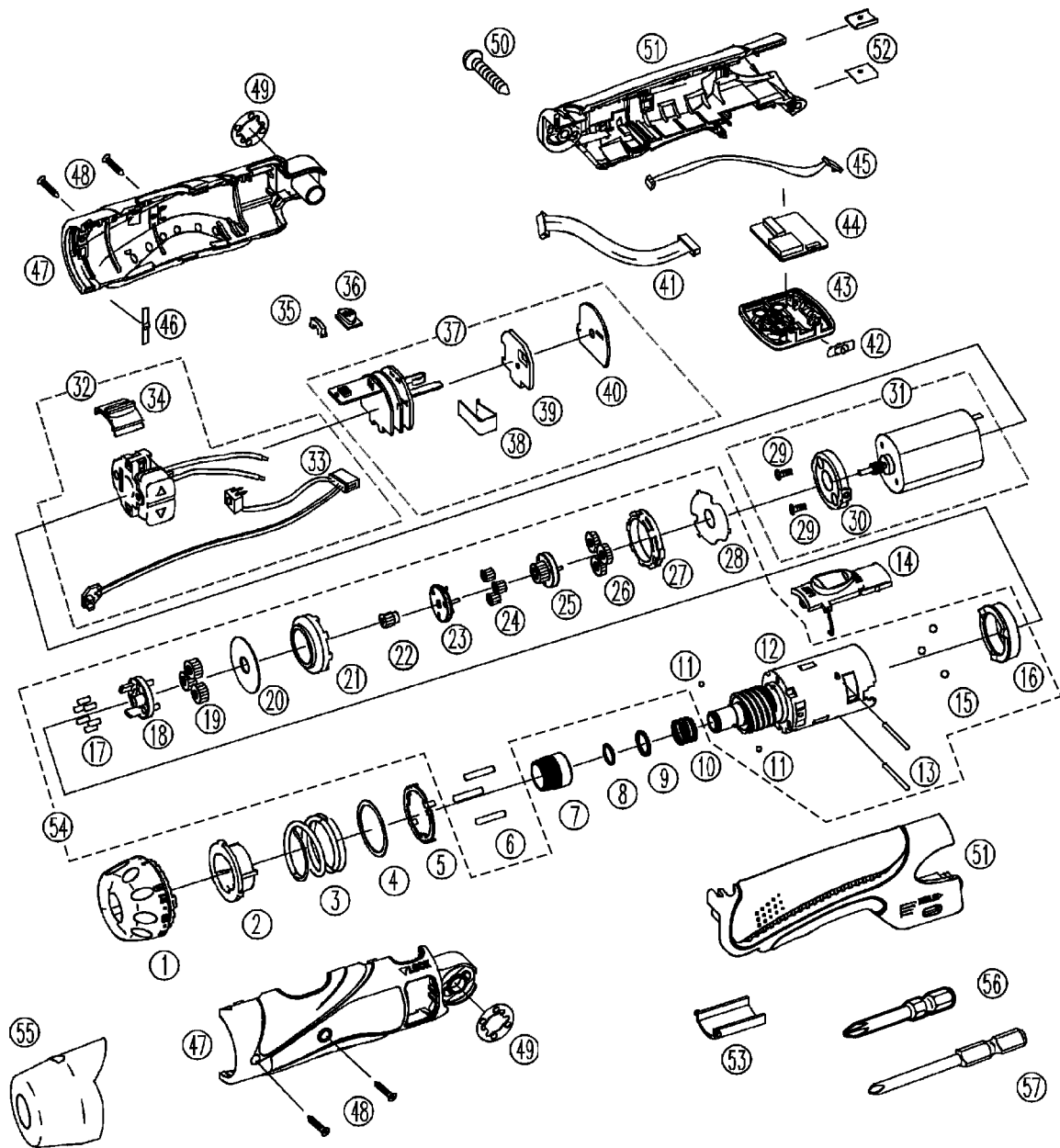

Production marking 7 digits
 6070001
 ┌ Serial No. (0001~)
 │ Month
 └ Year (last digits)

- ** Battery Pack is available as an optional accessory. See the nearest sales dealer for details.
- *** For replacement parts of charger, see the charger service manual.
 Charger complete set is available as an optional accessory. See the nearest sales dealer for details.

7.2. Replacement Parts List

Safety	Ref. No.	Part No.	Part Name & Description	Quantity	Remarks
	1	WEY7410K3227	CLUTCH HANDLE	1	
	2	WEY6225L0637	ADJUSTING SCREW	1	
	3	WEY6225L0167	CLUTCH SPRING	1	
	4	WEY7411L0317	RUBBER SHEET	1	(2*7.3)
	5	WEY6225L0847	CLUTCH PLATE	1	
	6	WEY6225L0397	PIN A	3	(ϕ 3*15.1), (3PCS/PK)
	7	WEY7410K3717	BIT HOLDER	1	
	8	WEY7410K1167	C-TYPE SPRING	1	
	9	WEY7410L0867	THRUST PLATE	1	
	10	WEY7410L0927	SPRING FOR BIT	1	
	11	WEY503B1927	STEEL BALL	2	(2PCS/PK)
	12	WEY7411L4057	GEAR CASE	1	
	13	WEY6225L0377	PIN C	2	(ϕ 2*22.8), (2PCS/PK)
	14	WEY7410H3237	CHANGE-GEAR HANDLE	1	
	15	WEY6225L6977	STEEL BALL	3	(ϕ 3.5), (3PCS/PK)
	16	WEY6225L1477	RING GEAR C	1	
	17	WEY6225L0387	PIN B	6	(ϕ 2.5*5.8), (6PCS/PK)
	18	WEY6225L1147	CARRIER D	1	
	19	WEY6225L1347	PLANET GEAR C	3	(3PCS/PK)
	20	WEY6225L0857	THRUST PLATE	1	
	21	WEY6225L1487	RING GEAR A	1	
	22	WEY6225L1117	CARRIER A	1	
	23	WEY6225L1127	CARRIER B	1	
	24	WEY6225L1367	PLANET GEAR B	3	(3PCS/PK)
	25	WEY6225L1137	CARRIER C	1	
	26	WEY6225L1357	PLANET GEAR A	3	(3PCS/PK)
	27	WEY6225L1497	RING GEAR B	1	
	28	WEY502B0207	INTERNAL PRESSURE	1	
	29	WEY6225L6027	SCREW	2	(K3-5)
	30	WEY6225L0027	MOTOR MOUNTING BASE	1	
	31	WEY7410L1008	DC MOTOR	1	
	32	WEY7410K2007	SWITCH	1	
	33	WEY7410L2127	DETECTION PCB	1	
	34	WEY7410H0397	LOCK LEVER	1	
	35	WEY7410X3117	BATTERY LOW WARNING LAMP COVER	1	
	36	WEY7410H3567	LED LIGHT ON/OFF BUTON	1	
	37	WEY7411L2117	CONTROL PCB	1	
	38	WEY6225L0197	SPRING	1	
	39	WEY7410L2567	RADIATING PLATE	1	
	40	WEY7410L0207	TERMINAL BASE PLATE	1	
	41	WEY7411L2897	COUNTER HARNESS	1	
	42	WEY7411L3567	HOLD SWITCH	1	
	43	WEY7411K3578	CONTROL PANEL	1	
	44	WEY7411L2147	COUNT MODULE	1	
	45	WEY7411L2337	LED MODULE	1	
	46	WEY6225L0177	CLICK SPRING	1	
	47	WEY7411K3059	HOUSING AB SET	1	
	48	WEY6230L6017	TAPPING SCREW	4	(2.6*8)
	49	WEY502B0187	CLICK SPRING	2	(2PCS/PK)
	50	WEY502B6217	TAPPING SCREW	1	(M4-20)
	51	WEY7411K3938	GRIP AB SET	1	
	52	WEY6225L0157	FASTENING CLIP	2	(2PCS/PK)
	53	WEY7410H0877	HINGE COVER	1	
	54	WEY7410L1087	GEAR BOX BLOCK	1	
	55	WEY7410L3107	CLUTCH LOCK COVER	1	
	56	WEY6225S7888	#1 PHILIPS BIT	1	(L=50MM)
	57	WEY6225S7958	#2 PHILIPS BIT	1	(L=50MM)
	-	WEY7411K8008	INDIVIDUAL BOX	1	(for LA1C)
	-	WEY7411K8009	INDIVIDUAL BOX	1	(for LA1S)
	-	WEY7411K8109	OPERATING INSTRUCTIONS	1	