

Service Manual

Cordless Multi Purpose Metal Cutter

Model No. **EY4542**

Europe
Oceania

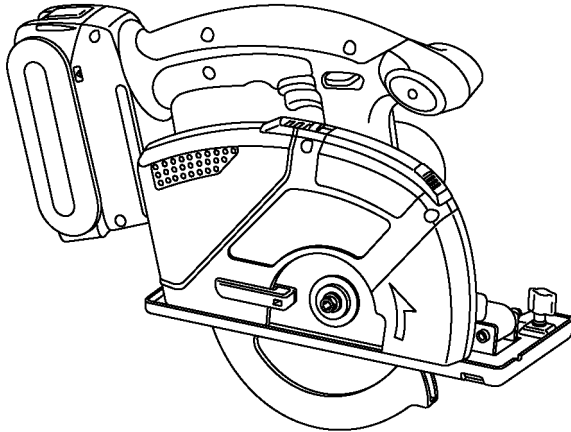

⚠ WARNING

This service information is designed for experienced repair technicians only and is not designed for use by the general public. It does not contain warnings or cautions to advise non-technical individuals of potential dangers in attempting to service a product. Products powered by electricity should be serviced or repaired only by experienced professional technicians. Any attempt to service or repair the product or products dealt with in this service information by anyone else could result in serious injury or death.

IMPORTANT SAFETY NOTICE

There are special components used in this equipment which are important for safety. These parts are marked by **⚠** in the Schematic Diagrams, Circuit Board Diagrams, Exploded Views and Replacement Parts List. It is essential that these critical parts should be replaced with manufacturer's specified parts to prevent shock, fire or other hazards. Do not modify the original design without permission of manufacturer.

TABLE OF CONTENTS

	PAGE	PAGE
1 Warning-----	2	
2 Specifications -----	2	
3 Troubleshooting Guide-----	3	
4 Disassembly and Assembly Instructions -----	5	
5 Wiring Connection Diagram -----	12	
6 Schematic Diagram-----	12	
7 Exploded View and Replacement Parts List -----	13	

Panasonic

© Panasonic Electric Works Co., Ltd. 2008.
All rights reserved. Unauthorized copying and distribution is a violation of law.

1 Warning

Caution:

- Pb free solder has a higher melting point than standard solder; Typically the melting point is 50 - 70°F (30 - 40°C) higher. Please use a soldering iron with temperature control and adjust it to 750 ± 20°F (400 ± 10°C). In case of using high temperature soldering iron, please be careful not to heat too long.
- Pb free solder will tend to splash when heated too high (about 1100°F / 600°C).

2 Specifications

MAIN UNIT

Motor		14.4V DC
Blade speed		3600 min ⁻¹ (rpm)
Blade size	Outside diameter	135mm (5-3/8")
	Arbor size	20mm (25/32")
Maximum cutting depth		0 – 46mm (0" – 1-13/16") (φ 135mm blade)
Overall length		329mm (12-61/64")
Weight (with battery pack EY9L40)		2.65kg (5.7lbs.)

3 Troubleshooting Guide

(Refer to Wiring Connection Diagram)

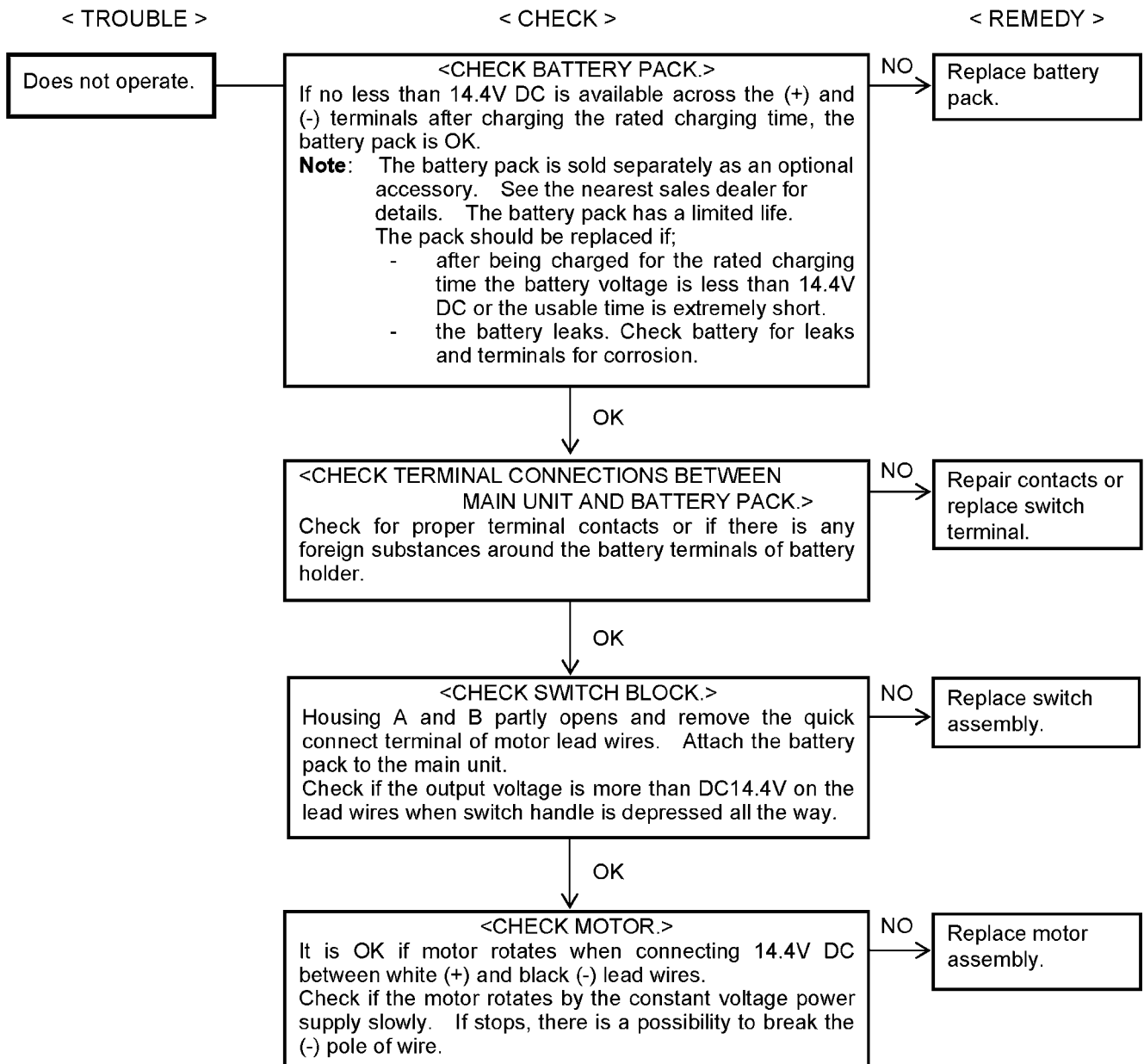

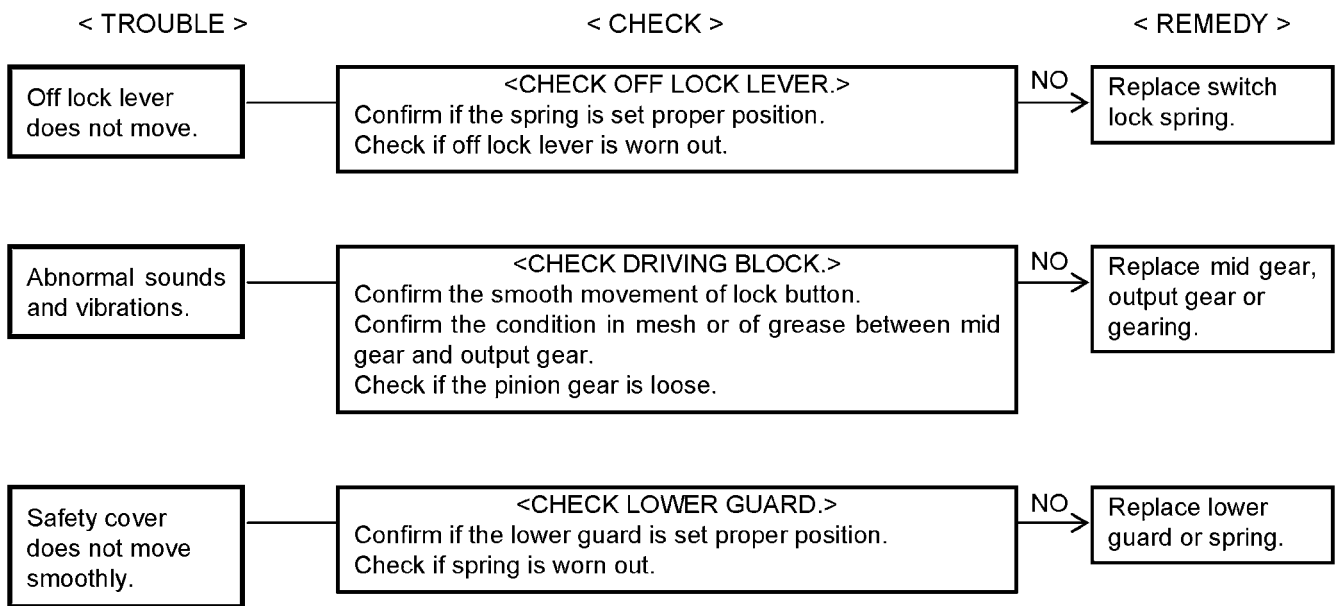

3.1. Trial Operation (after checking Troubleshooting Guide.)

1. ASSEMBLY

- Confirm if there is NO gap between Housing A and B by pinching the lead wires.
- Confirm if there is NO deformation on the battery terminals.
- Confirm all screws are tightened firmly.
- Confirm the smooth movement of lower guard, switch button and off-lock lever.

2. Operation

- There should be no metallic sound, abnormal sound or abnormal vibration.
- Confirm if the unit does not get hot in rapidly and abnormally.

4 Disassembly and Assembly Instructions

4.1. How to Disassemble the Blade.

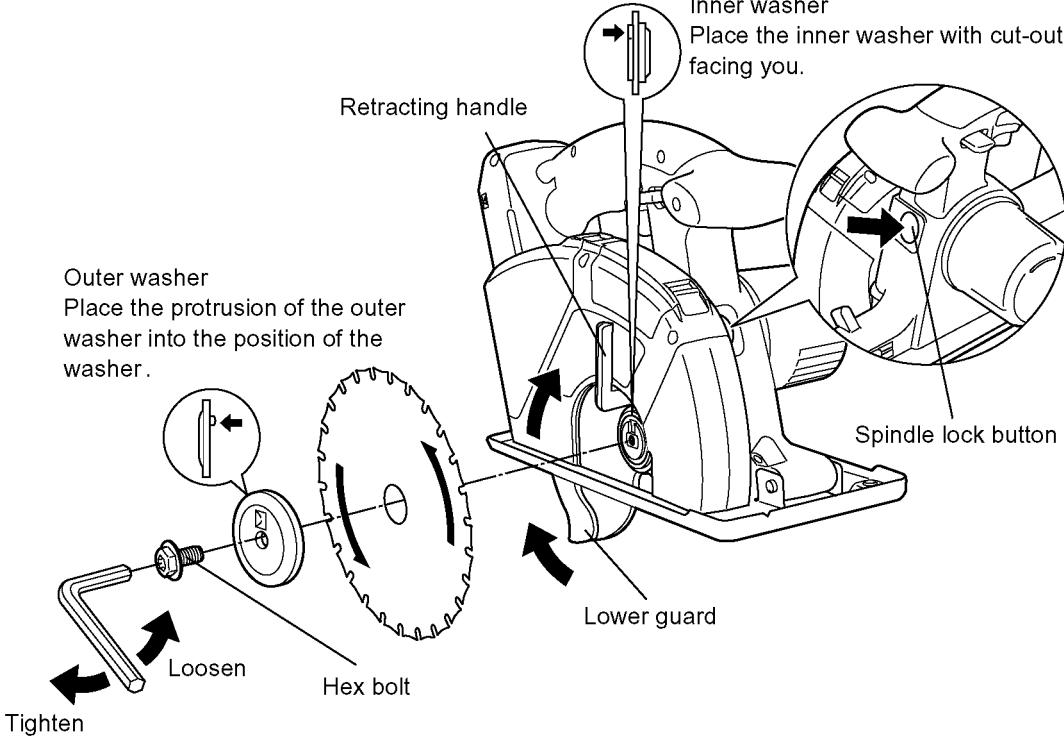
Ref. No. 1A	Procedure 1A	Blade removal.
		<p>CAUTION: The blade will be hot right after cutting. Be sure to let the blade cool down before removing it.</p> <ol style="list-style-type: none">1. Remove the battery pack from the tool.2. Hold the spindle lock button down. This prevents the blade from rotation.3. Use the provided hex wrench to loosen the hex bolt. <p>NOTE: Keep the hex wrench in the storage slot on the tool's body when not using it.</p> <ol style="list-style-type: none">4. Remove the hex bolt and outer washer.5. Use the retracting handle to retract (open) the lower guard.6. Carefully remove the blade.7. Clean the tool if necessary. <p>CAUTION: Be careful to avoid cutting your hands on the blade.</p>
 <p>Outer washer Place the protrusion of the outer washer into the position of the washer.</p> <p>Retracting handle</p> <p>Inner washer Place the inner washer with cut-out facing you.</p> <p>Spindle lock button</p> <p>Lower guard</p> <p>Hex bolt</p> <p>Loosen</p> <p>Tighten</p>		

4.2. How to Reassemble the Main Unit.

(The main unit can be opened without removing the shoe.)

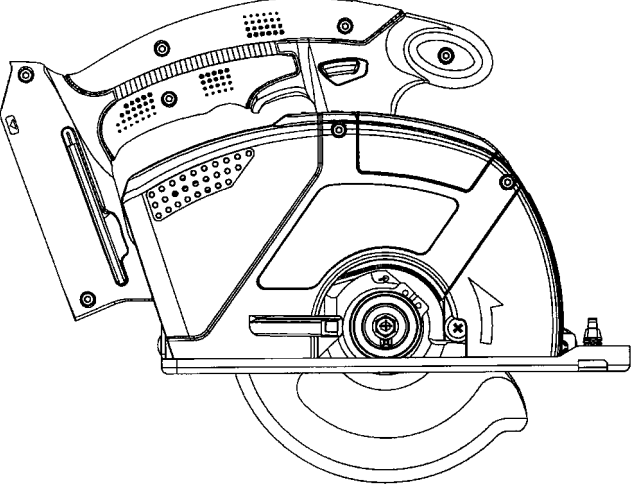
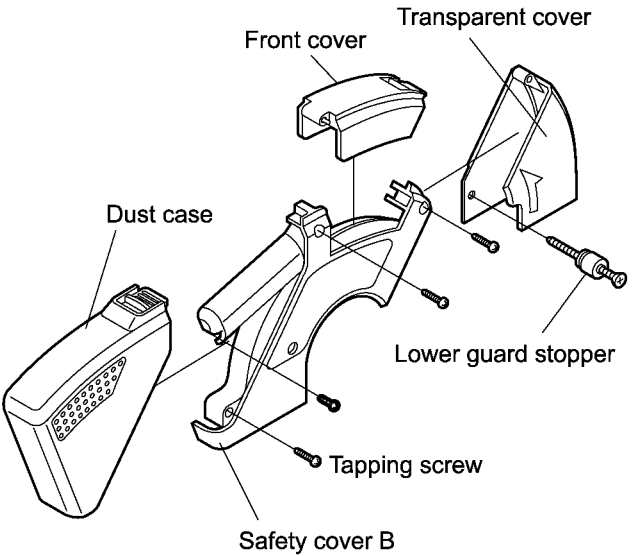
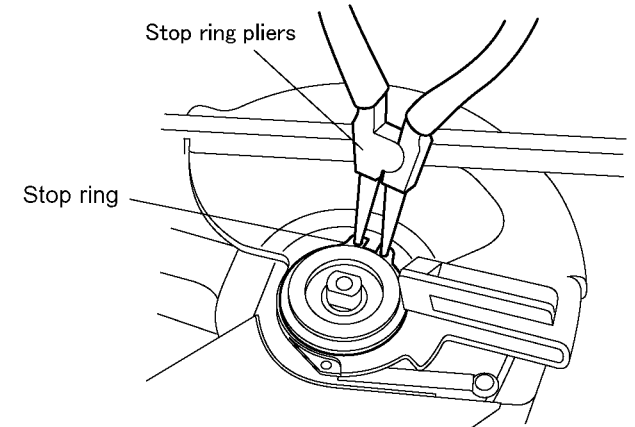
Ref. No. 2A	Procedure 2A	Removal of the lower guard.
		<ol style="list-style-type: none">1. Remove the dust case.2. Remove the 4 screws securing the safety cover B. Take out the safety cover B.3. Remove the lower guard stopper.4. Take out the front cover and transparent cover.5. Remove the inner washer and the stop ring.6. Remove the lower guard with connecting the spring. <p>NOTE: When removing the lower guard from the main unit, do not stretch the spring.</p>
		
		

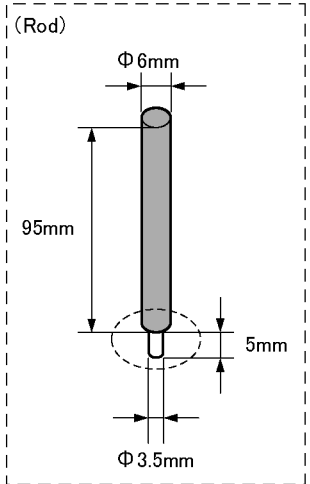
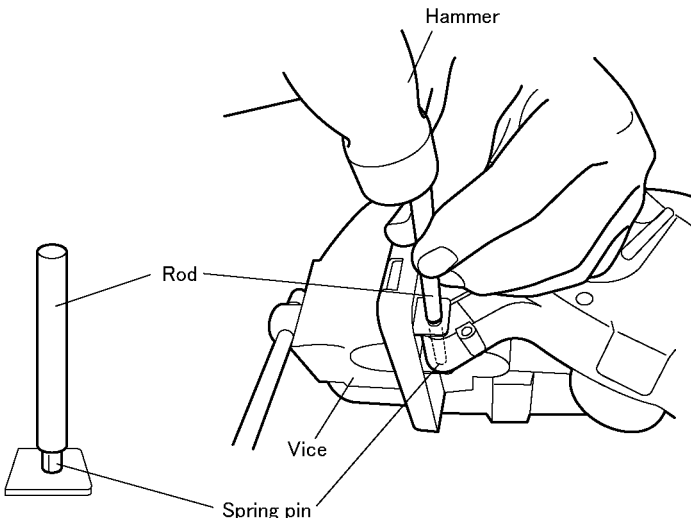
Ref. No. 2B	Procedure 2A → 2B	Removal of the shoe.
 <p>(Rod)</p> <p>Φ 6mm</p> <p>95mm</p> <p>5mm</p> <p>Φ 3.5mm</p>		<p>NOTE: It is possible to disassemble the main unit without removing the shoe.</p> <ol style="list-style-type: none"> 1. Hold the unit with the vice. 2. Push out the spring pin with a rod having a diameter of 6mm. <p>NOTE: Do not tap the spring pin strongly. If to do so, the hole of spring may cause the deformation.</p>  <p>Hammer</p> <p>Rod</p> <p>Vice</p> <p>Spring pin</p>

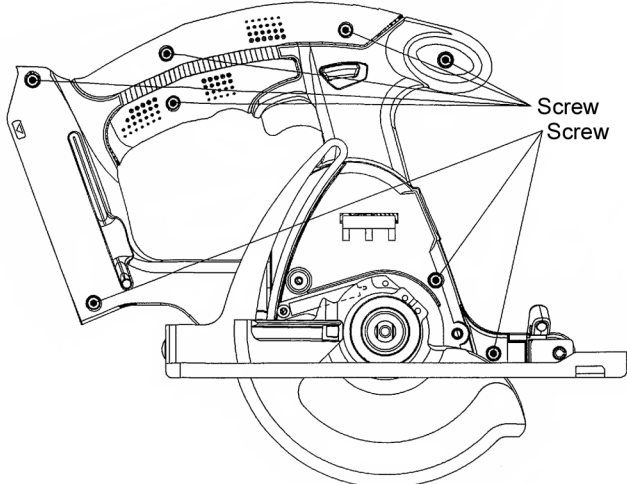
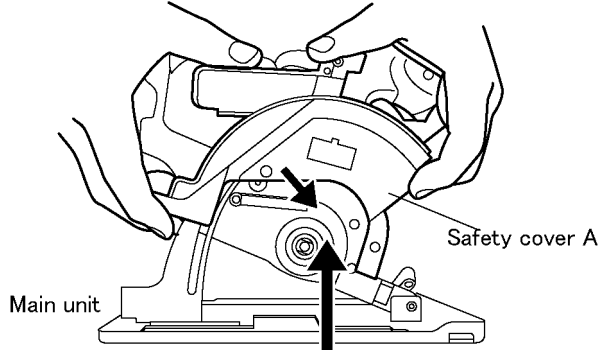
Ref. No. 2C	Procedure 2A → 2C	Removal of the Housing.
 <p>Screw</p> <p>Screw</p>		<ol style="list-style-type: none"> 1. Loosen depth adjustint nut and take out square screw. 2. Loosen 8 housing screws. 3. Slightly pull the safety cover A forward and then pull it upward. <p>It is then possible to disassembly the main unit or to check the switch block and motor.</p> <p>NOTE: Do not remove a screw that holds spring except in the case of damage.</p>  <p>Safety cover A</p> <p>Main unit</p>

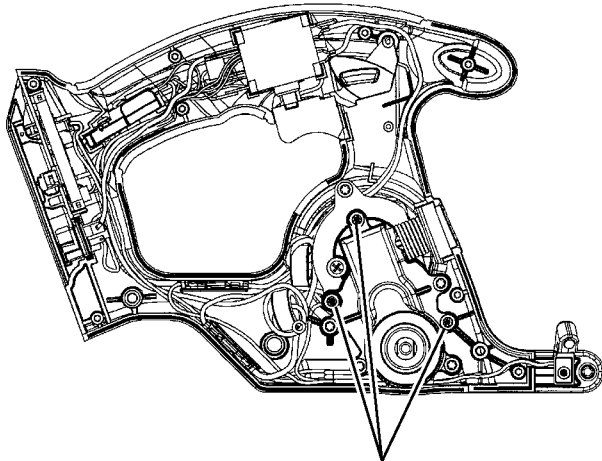

Screw

1. Remove the off lock lever and the off lock spring.
2. Loosen 3 screws where securing the driving block with the housing in order to take out the gear box block from the main unit.
3. Press the shaft lock button and carefully remove the driving block assembly.
4. Remove 5 screws and carefully open the gear box housing.

NOTE:

The internal parts of gear box block can be removed one after another.

NOTE:

The lock button spring may pop out if it is not pushed in while removing the driving block.

4.3. How to Assemble the Main Unit.

CAUTION:

The proper operation of the “off lock lever” is critical for the safe use and operation of the cutter. Be extra careful in re-assembling the unit and ensure that the “off lock lever” is properly positioned. Verify the operation of the “off lock lever” upon completing the re-assembly procedure. Ensure that the power switch can only be activated after depressing the “off lock lever”

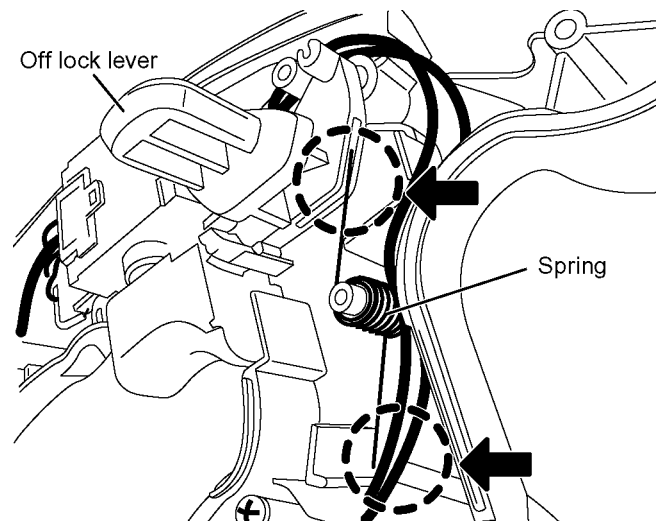
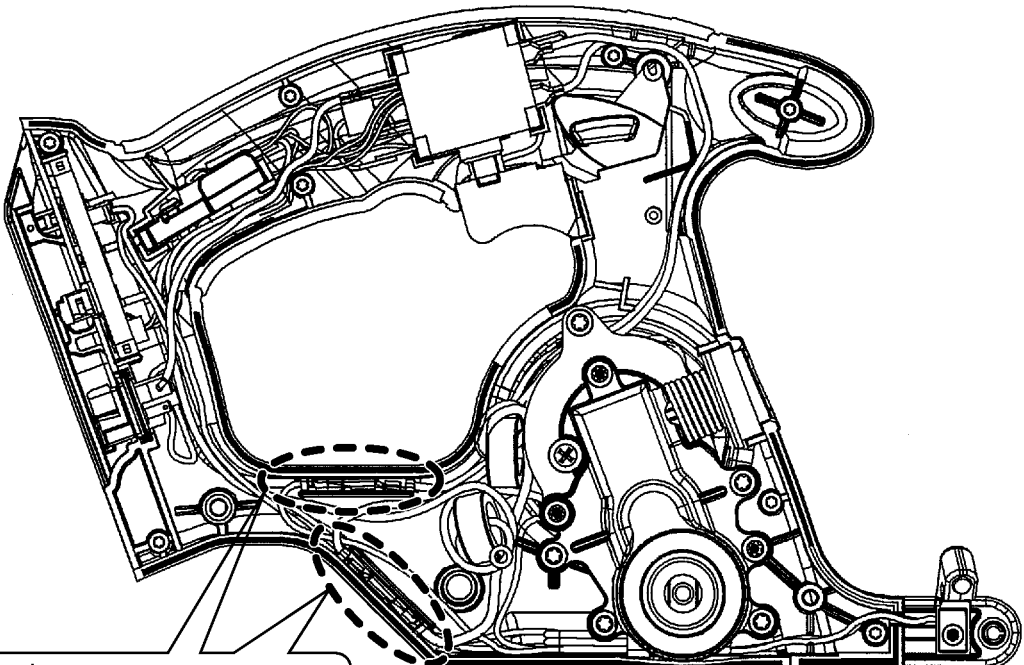
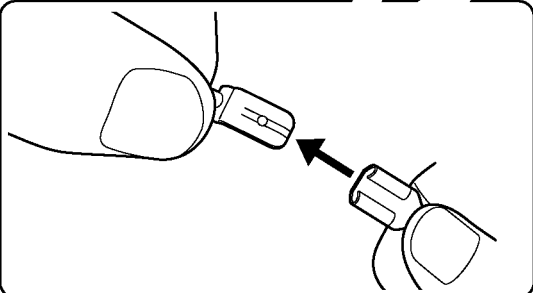
Ref. No. 3A	Procedure 3A	Assembly of the driving assembly.
	 <p>Off lock lever</p> <p>Spring</p>	<p>When installing the driving block into the housing;</p> <ol style="list-style-type: none">1. Put the off lock lever into the housing boss.2. Insert the one side of lever spring into the groove of the off lock lever. And Hitch the other side of lever spring on the housing rib.3. Push and hold the spindle lock button while inserting the driving block into the housing.  

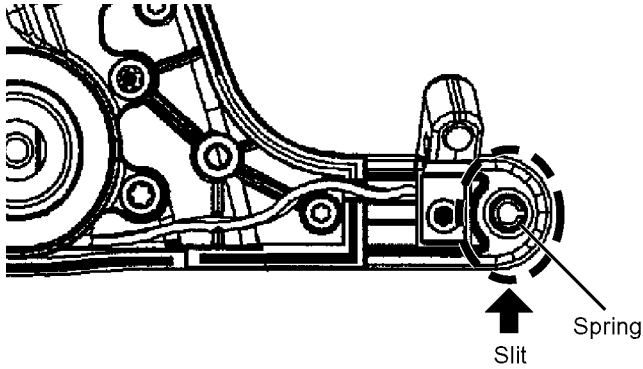

1. Insert the spring pin with a rod having a diameter of 5mm.

NOTE:

Make sure that the slit part of spring is placed downward. And protrusion of spring pin should be uniform on both side.

1. Tighten 8 housing screws.

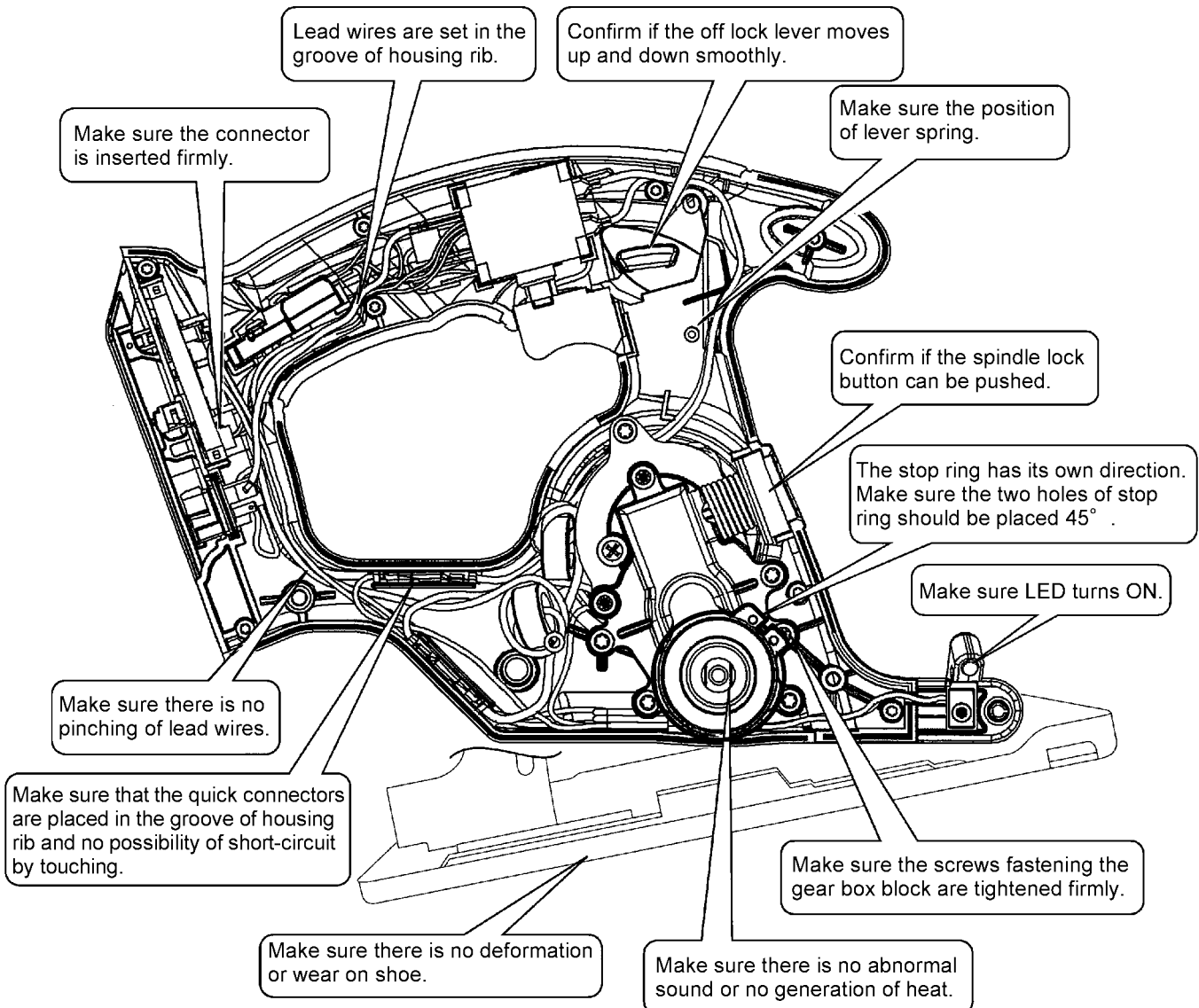

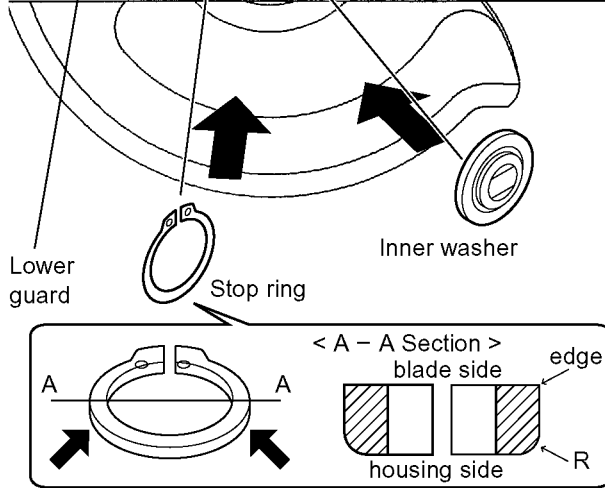
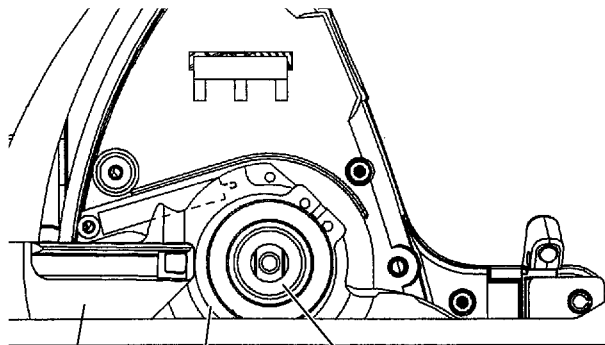

1. Set the safty cover A with connecting the transparent guard and tighten a screw.
2. Set the front cover and the safety cover B.
3. Tighten 4 screws on the safety cover B and a screw on the transparent guard.
4. Set the stop ring.

NOTE:

- The stop ring has its own direction for assembly. Make sure that the rounded side faces housing.
 - And make sure that 2 holes of stop ring should be placed upper right.
5. Set the inner washer and carefully set the blade.
 6. Set the outer washer and tighten the hex bolt using the provided hex wrench with holding the spindle lock button.

5 Wiring Connection Diagram

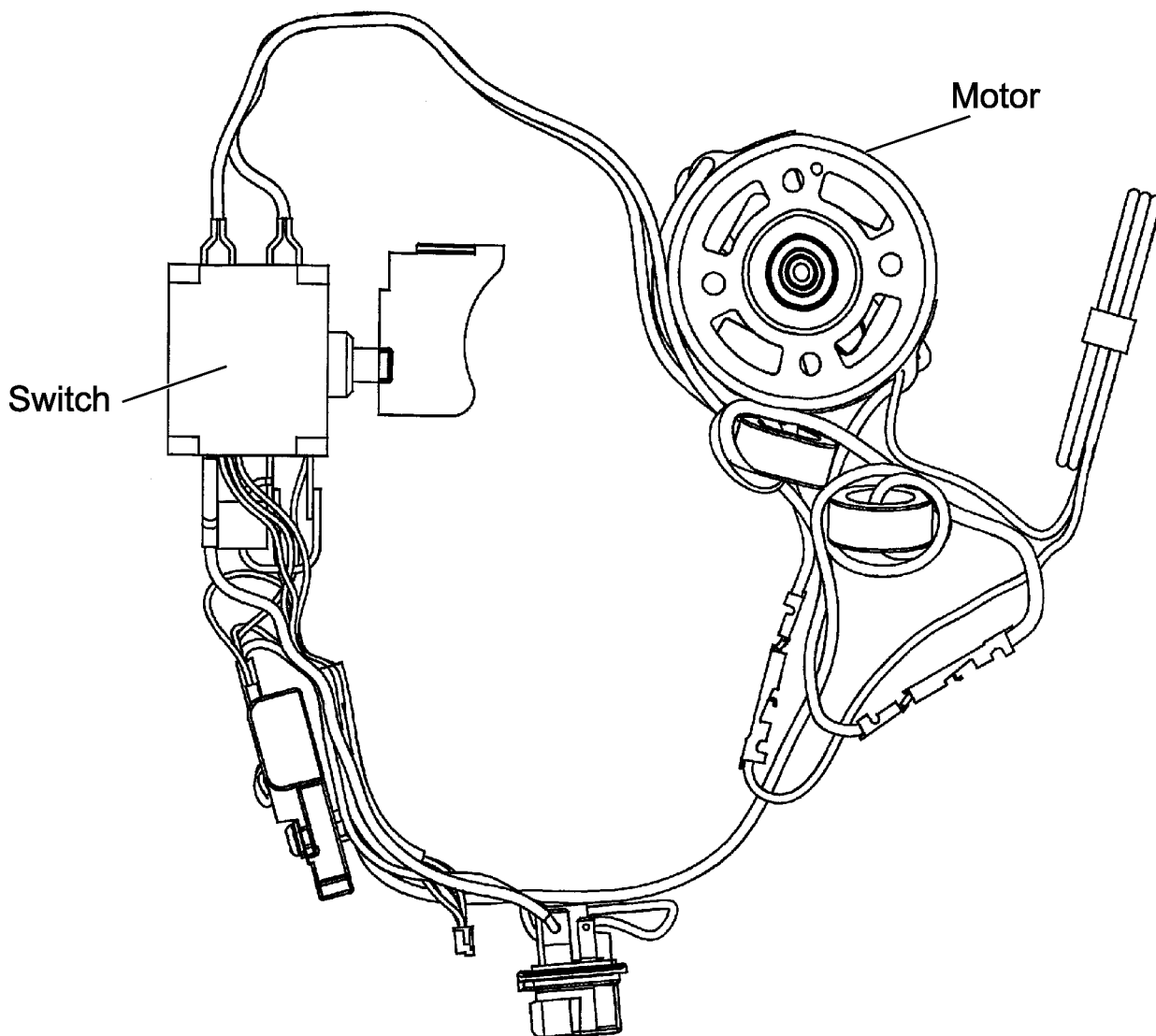

6 Schematic Diagram

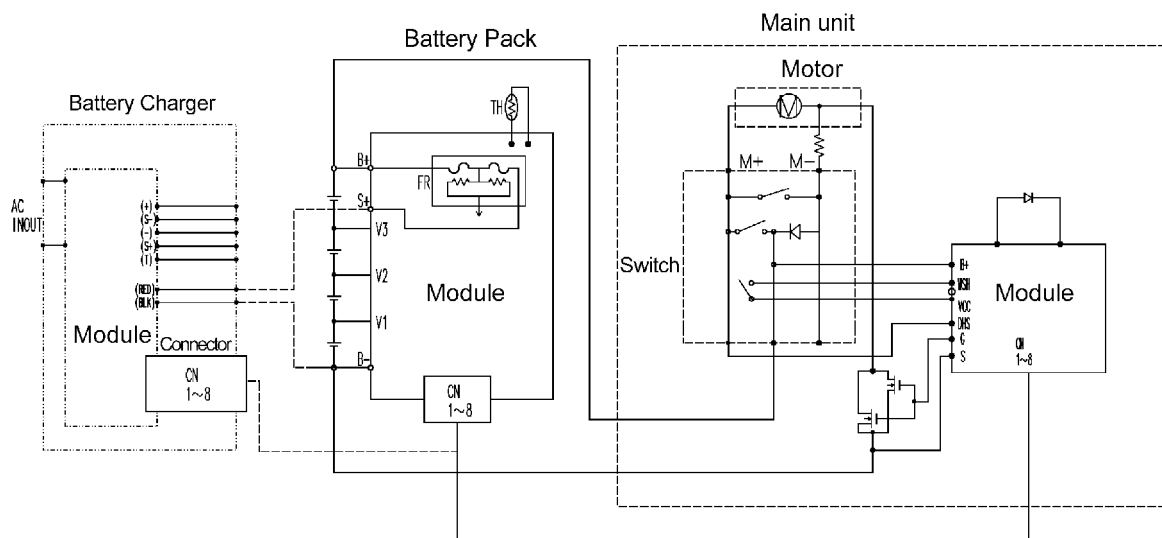

7 Exploded View and Replacement Parts List

Model No. : EY4542 Exploded View

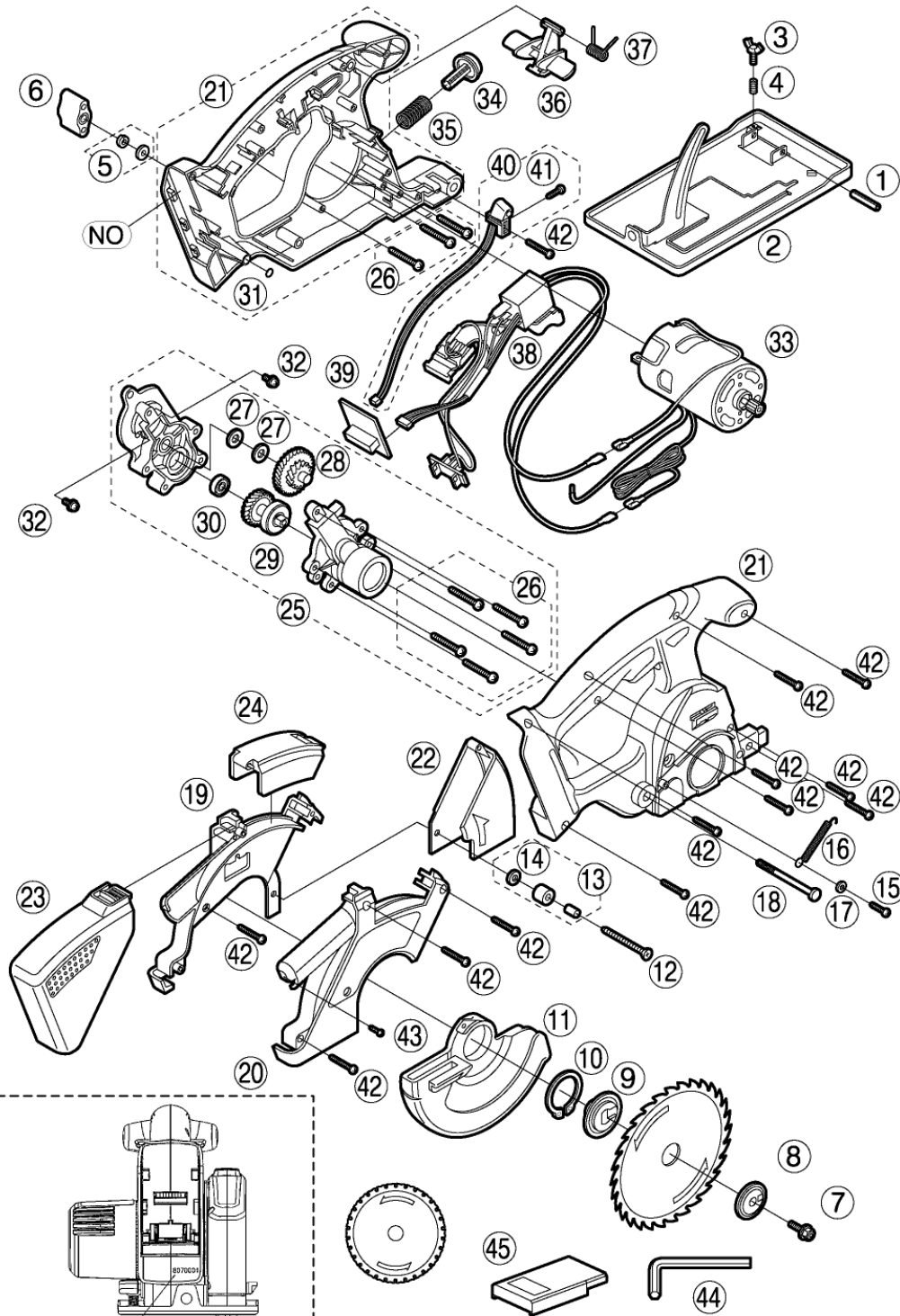

Production marking 7 digits

8 07 0001
 └───┬───┬─── Serial No.
 └───┬───┬─── Month
 └───┬───┬─── Last digit of year

** Battery Pack and Blade are available as an optional accessory. See the nearest sales dealer for details.

*** For replacement parts of charger, see the charger service manual. Charger complete set is available as an optional accessory. See the nearest sales dealer for details.

Model No. : EY4542 Parts List

Safety	Ref. No.	Part No.	Part Name & Description	Q'ty	Remarks
	1	WEY3500K0356	SPRING PIN	1	(φ6-45)
	2	WEY4542S3427	SHOE	1	
	3	WEYT502K6487	ADJUSTING BOLT	1	
	4	WEY3503K0196	SPRING	1	(φ7.6*15)
	5	WEY3530S6387	WASHER	1	(φ5)
	6	WEY3503K0896	DEPTH ADJUSTING NUT	1	
	7	WEY3530K6256	FLANGE SOCKET	1	(M5*12)
	8	WEY3501K1176	OUTER WASHER	1	
	9	WEY3503L1166	INNER WASHER	1	
	10	WEY3503L0426	STOP RING	1	
	11	WEY3530K1196	LOWER GUARD	1	
	12	WEY3503S9386	TAPPING SCREW	1	(4*40)
	13	WEY3510K0397	LOWER GUARD STOPPER	1	
	14	WEY4542Y6457	WASHER	1	(φ4)
	15	WEY3503K9037	TAPPING SCREW	1	(K3-12)
	16	WEY3503L0926	SPRING	1	(φ5.45*49)
	17	WEY4542S6457	WASHER	1	(φ3)
	18	WEY4542L6537	SQUARE SCREW	1	(M5)
	19	WEY4542K3107	SAFETY COVER A	1	
	20	WEY4542K3128	SAFETY COVER B	1	
	21	WEY4542K3079	HOUSING AB SET	1	(for EUROPE)
	21	WEY4542K3070	HOUSING AB SET	1	(for OCEANIA)
	22	WEY4542X3117	TRANSPARENT COVER	1	
	23	WEY4542X3047	DUST CASE	1	
	24	WEY4542X3147	FRONT COVER	1	
	25	WEY4542L1458	GEAR BOX ASSEMBLY	1	
	26	WEY3503K6206	FREARSON SCREW	8	(K4*20)
	27	WEY3503L0846	THRUST PLATE	2	
	28	WEY3530L1437	MID GEAR	1	
	29	WEY4542L4057	OUTPUT GEAR	1	
	30	WEY4542L0387	BEARING	1	
	31	WEY3530L0976	O RING	1	
	32	WEY4542L6067	SCREW	2	(K5*8), (2PCS/PK)
	33	WEY4542L1008	MOTOR ASSEMBLY	1	
	34	WEY4542H0367	SPINDLE LOCK BUTTON	1	
	35	WEY3500K0196	LOCK BUTTON SPRING	1	(15.4*37)
	36	WEY4542H3237	OFF LOCK LEVER	1	
	37	WEYT502L0917	OFF LOCK SPRING	1	
	38	WEY4542L2007	SWITCH	1	
	39	WEY4542L2107	MAIN PCB ASSEMBLY	1	
	40	WEY4542L2117	LED ASSEMBLY	1	
	41	WEY4542K9447	TAPPING SCREW	1	(2*5)
	42	WEY7440K9038	TAPPING SCREW	13	(K3*20)

Model No. : EY4542 Parts List

Safety	Ref. No.	Part No.	Part Name & Description	Q'ty	Remarks
	43	WEY4542L9257	TAPPING SCREW	1	(K2*10)
	44	WEY3542K7867	HEX WRENCH	1	
	45	WEY9L40R2788	BATTERY PACK COVER	1	
	-	WEY9642K7018	TOOL CASE	1	<SH>
	-	WEY9643K7108	SOFT CASE	1	<SH>
	-	WEY4542K8008	WRAPPER	1	<SH>
	-	WEY4542K8109	OPERATING INSTRUCTIONS	1	<SH>