

Service Manual

Cordless Drill & Driver
Cordless Hammer Drill & Driver
Model No. EY7460
EY7960

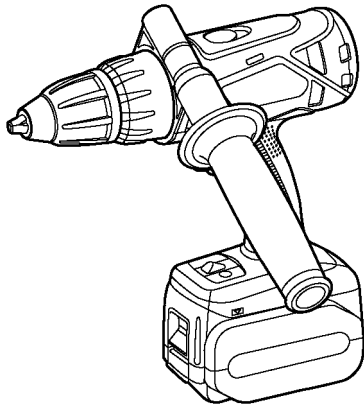

Europe
 Oceania

⚠ WARNING

This service information is designed for experienced repair technicians only and is not designed for use by the general public. It does not contain warnings or cautions to advise non-technical individuals of potential dangers in attempting to service a product. Products powered by electricity should be serviced or repaired only by experienced professional technicians. Any attempt to service or repair the product or products dealt with in this service information by anyone else could result in serious injury or death.

IMPORTANT SAFETY NOTICE

There are special components used in this equipment which are important for safety. These parts are marked by ⚠ in the Schematic Diagrams, Circuit Board Diagrams, Exploded Views and Replacement Parts List. It is essential that these critical parts should be replaced with manufacturer's specified parts to prevent shock, fire or other hazards. Do not modify the original design without permission of manufacturer.

TABLE OF CONTENTS

	PAGE	PAGE
1 Warning -----	2	
2 Specifications -----	2	
3 Troubleshooting Guide -----	3	
4 Disassembly and Assembly Instructions -----	6	
5 Wiring Connection Diagram -----	10	
6 Schematic Diagram -----	10	
7 Exploded View and Replacement Parts List -----	11	

1 Warning

Caution:

- Pb free solder has a higher melting point than standard solder; Typically the melting point is 50 - 70°F (30 - 40°C) higher. Please use a soldering iron with temperature control and adjust it to 750 ± 20°F (400 ± 10°C). In case of using high temperature soldering iron, please be careful not to heat too long.
- Pb free solder will tend to splash when heated too high (about 1100°F / 600°C).

2 Specifications

MAIN UNIT

Model		EY7460	EY7960
Motor voltage		21.6V DC	
No load speed	LOW	100-400 min ⁻¹ (rpm)	
	HIGH	350-1500 min ⁻¹ (rpm)	
Blows rate per minute	LOW	-----	1800-7200 min ⁻¹ (bpm)
	HIGH	-----	6300-27000 min ⁻¹ (bpm)
Chuck capacity		ϕ 1.5mm – ϕ 13mm (1/16" – 1/2")	
Chuck torque		Approx. 1.0 N·m (10kgf-cm, 8.8 in-lbs) – 6.9 N·m (70kgf-cm, 61 in-lbs)	
Overall length		232mm (9-1/8")	245mm (9-5/8")
Weight (with battery pack)		2.45kg (5.39lbs.)	2.55 kg (5.61lbs.)

MAXIMUM RECOMMENDED CAPACITIES

Model		EY7460	EY7960
Screw driving	Machine screw	M8	
	Wood screw	∅ 10 mm (3/8")	
	Self-drilling screw	∅ 6 mm (15/64")	
Drilling	for Wood	∅ 38 mm (1-1/2")	
	for Metal	∅ 13 mm (1/2")	
	for Masonry	-----	13 mm (1/2")

3 Troubleshooting Guide

(Refer to Wiring Connection Diagram)

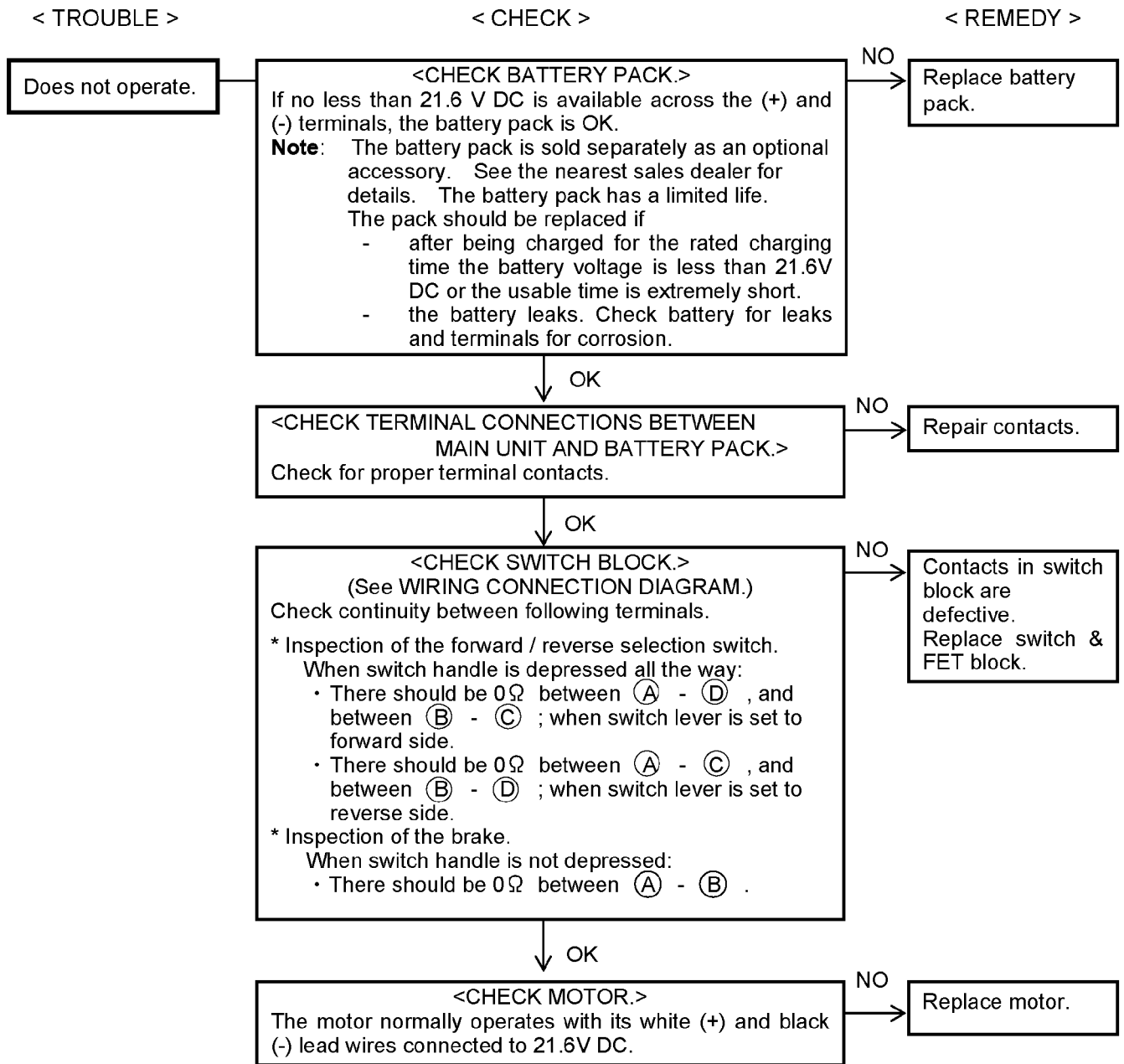

■ for EY7960 only

< TROUBLE >

< CHECK >

< REMEDY >

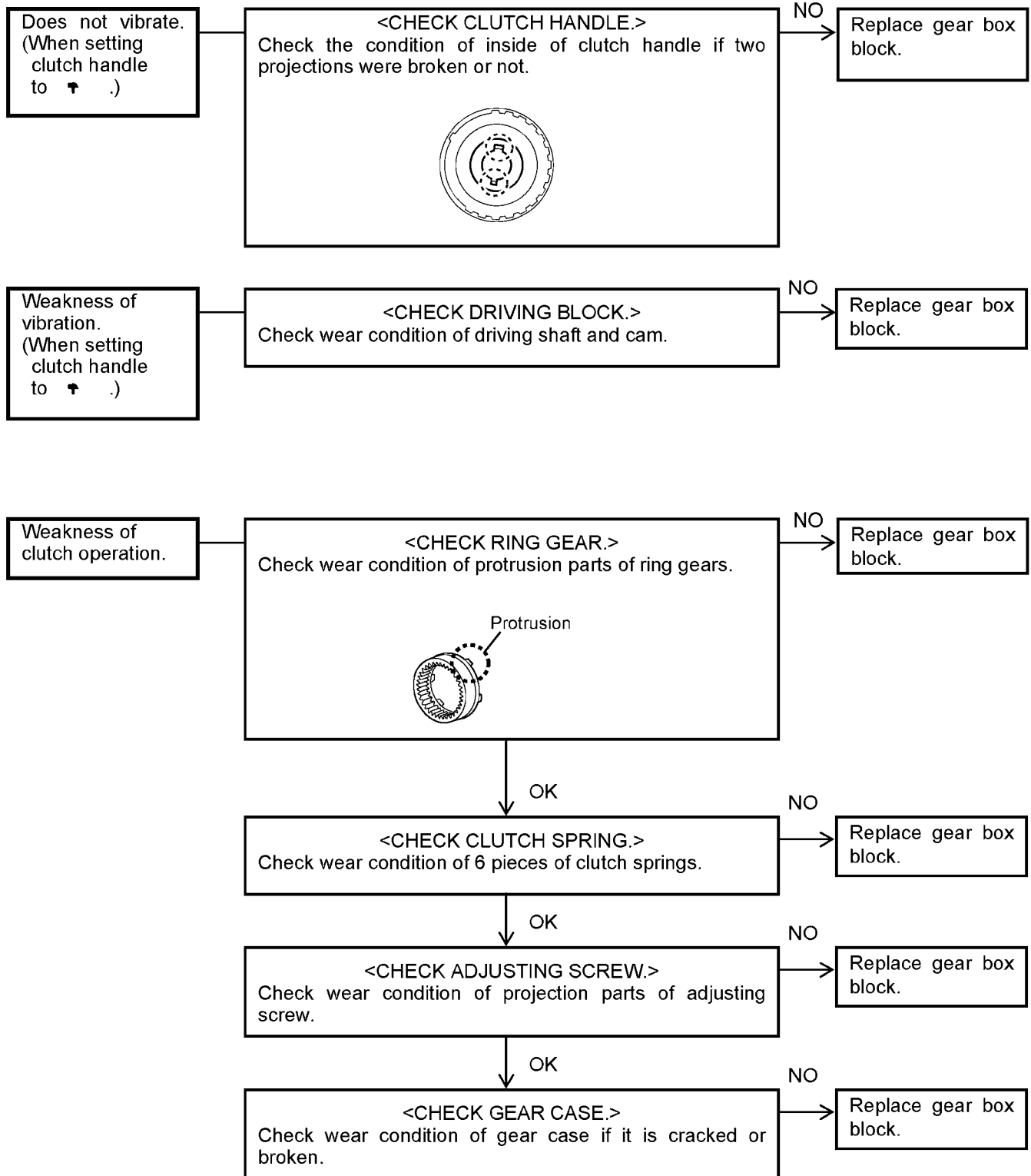

3.1. Trial Operation (after checking Troubleshooting Guide.)

1. HAMMER/DRILL

Confirm to adjust the torque to HAMMER mode.

Rotation with hammering may work when the drill bit touches something like concrete or hard type of wood block. And confirm the power.

It is OK, if it takes about 4-6 seconds by 20kgf to hole (Φ 6X30) on the concrete.

Confirm the action when setting the DRILL mode.

No hammering when the drill bit touches something like concrete or hard type of wood block.

And confirm the forward and reverse side of rotation.

2. SWITCH

Confirm the rotation of speed if it changes between 350 - 1650 rpm in proportion to the amount of pushing level on switch handle on HIGH mode.

3. CLUTCH

Check if the clutch torque changes suited for the number of clutch.

Check if the bit does not slip on Drilling mode.

4. ASSEMBLY

Confirm if there is NO gap between Housing A and B by pinching the lead wires.

Confirm all screws are tightened firmly.

There should be no metallic sound and abnormal sound.

4 Disassembly and Assembly Instructions

4.1. How to Disassemble Keyless Chuck.

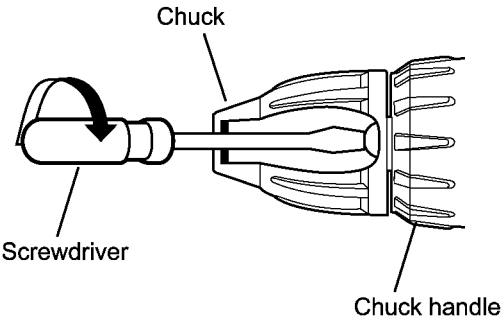
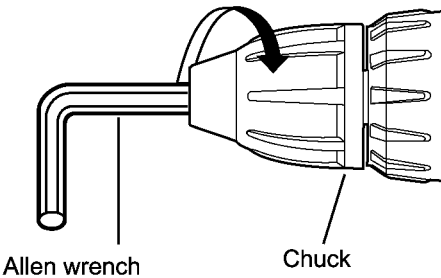
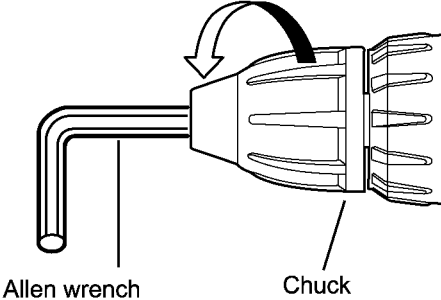
Ref. No. 1A	Procedure 1A	Removal of the Keyless Drill Chuck.
	 <p data-bbox="405 712 461 739">Fig. 1</p>	<p data-bbox="793 338 1206 365">Removal of the Keyless Drill Chuck.</p> <ol data-bbox="793 365 1463 495" style="list-style-type: none"><li data-bbox="793 365 1463 392">1. Set the clutch handle to position 1 and select "LOW" position.<li data-bbox="793 392 1463 418">2. Turn the lock collar counterclockwise direction to open the chuck jaws.<li data-bbox="793 418 1463 495">3. Use a screwdriver to turn the chuck fastening screw inside the chuck clockwise direction of the arrow, and remove the screw. (See Fig. 1). <p data-bbox="793 495 868 521">NOTE:</p> <p data-bbox="793 521 1463 629">If the chuck fastening screw will not come loose, insert the allen wrench into the chuck and lightly tap in the clockwise direction with a hammer to tighten the chuck, and then loosen the chuck fastening screw. (See Fig. 2).</p> <ol data-bbox="793 629 1463 705" style="list-style-type: none"><li data-bbox="793 629 1463 705">4. Insert the allen wrench into the chuck, and turn counterclockwise direction in the arrow with holding the unit by the vise to remove the chuck. (See Fig. 3).
	 <p data-bbox="405 1131 461 1158">Fig. 2</p>	
	 <p data-bbox="405 1541 461 1568">Fig. 3</p>	

4.2. How to Disassemble Main Unit.

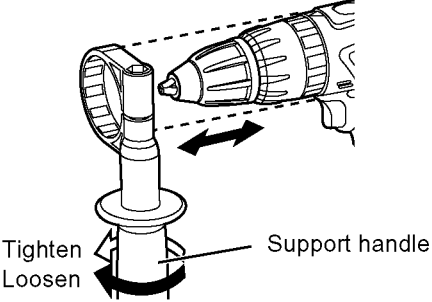
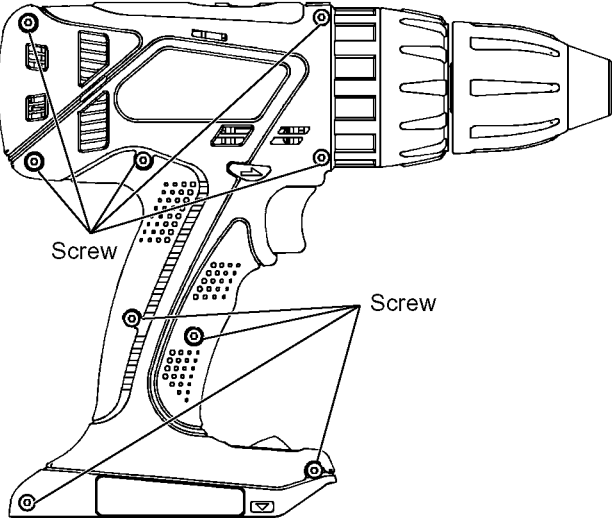
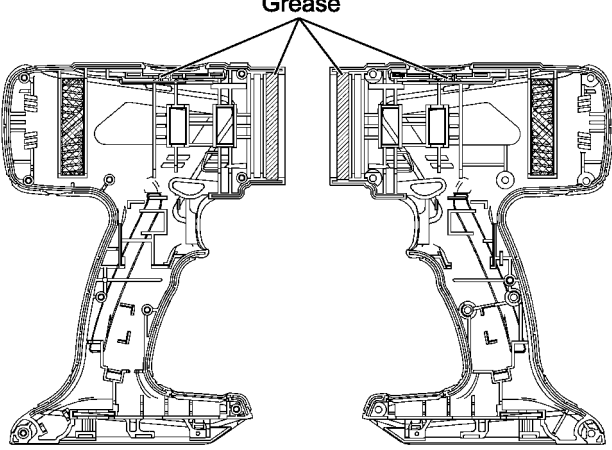
Ref. No. 2A	Procedure 2A	Removal of the Housing.
 <p data-bbox="300 526 734 593">Tighten Loosen</p> <p data-bbox="558 526 734 548">Support handle</p> <p data-bbox="446 627 502 649">Fig. 4</p>  <p data-bbox="223 929 295 952">Screw</p> <p data-bbox="542 985 614 1008">Screw</p> <p data-bbox="446 1243 502 1265">Fig. 5</p>	<p data-bbox="829 248 1117 271">Removal of the Housing.</p> <ol data-bbox="829 248 1260 302" style="list-style-type: none"> 1. Remove the support handle. (See Fig. 4). 2. Remove nine housing screws. (See Fig. 5). <p data-bbox="829 302 909 324">NOTE:</p> <p data-bbox="861 324 1468 380">Grease rubbing part of housing with Shell Alvania for assembly. (See Fig. 6)</p>  <p data-bbox="1125 403 1212 425">Grease</p> <p data-bbox="1141 896 1197 918">Fig. 6</p>	

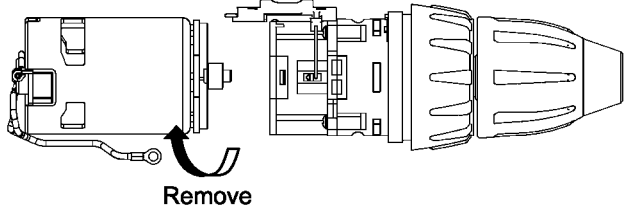
Ref. No. 2B	Procedure 2A → 2B	Removal or attachment of the Motor.
 <p data-bbox="335 1590 430 1612">Remove</p> <p data-bbox="462 1646 518 1668">Fig. 7</p>	<p data-bbox="861 1370 973 1393">(Removal)</p> <ol data-bbox="861 1393 1500 1478" style="list-style-type: none"> 1. Take out the motor with the gear box block from housing. 2. Separate the motor from the gear box block by twisting the motor to unlock tabs. (See Fig. 7) <p data-bbox="861 1500 989 1523">(Attachment)</p> <p data-bbox="861 1523 1500 1579">Motor mounting base and the positioning rib of gear case should be set.</p>	

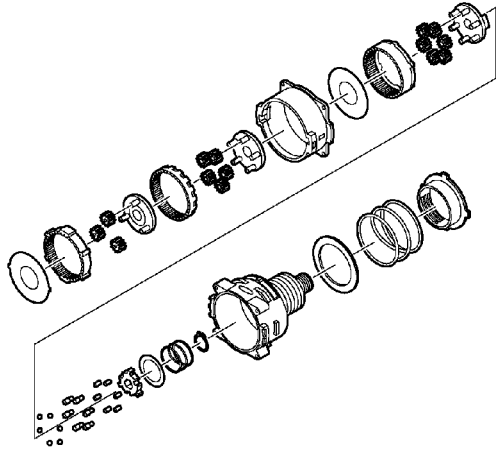

Fig. 8

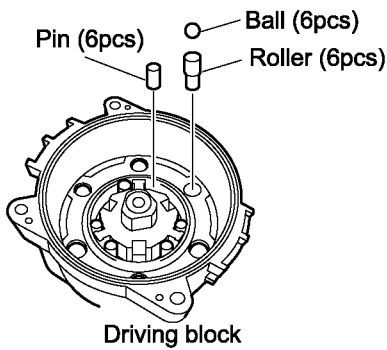

Fig. 9

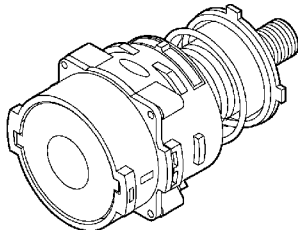

Fig. 10

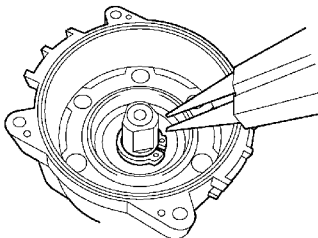

Fig. 11

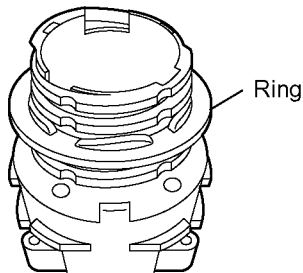

Fig.

EY7460

(Removal)

1. Turn the thrust plate to remove.
2. The internal parts of gear box block can be removed one after another. (See Fig. 8)

(Attachment)

1. Start from inserting 6 rollers and balls into the holes of driving block one of each as shown in the Fig. 9.
2. Insert 6 pins into the driving block as shown in the Fig. 9.
3. Assemble the other parts in reverse order as shown in the Fig. 8.

NOTE:

Carrier, Ring gear, and Clutch plate have their own correct directions for proper assembly.

EY7960

(Removal)

1. Turn the thrust plate to remove.
2. The internal parts of gear box block can be removed one after another. (See Fig. 10)

NOTE:

Adjusting screw can not be taken out without disassembling inside of the gear box block.

(Attachment)

1. Set the E-type ring.
2. Start from inserting 6 rollers and balls into the holes of driving block one of each as shown in the Fig. 9.
3. Insert 6 pins into the driving block as shown in the Fig. 9.
4. Assemble the other parts in reverse order as shown in the Fig. 8.

NOTE:

Carrier, Ring gear, and Clutch plate have their own correct directions for proper assembly.

5. Set the ring as shown in the Fig. 12.

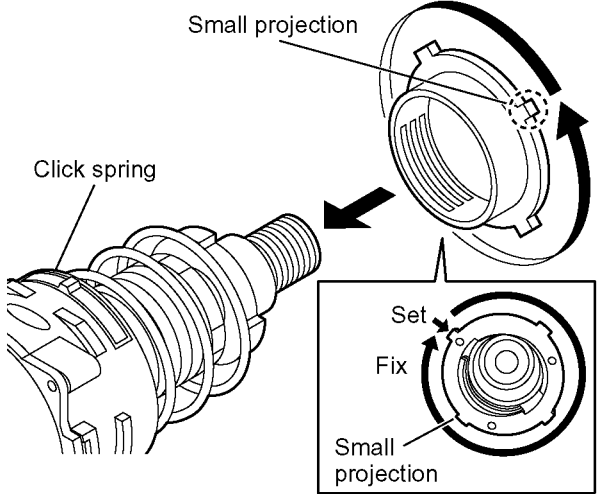
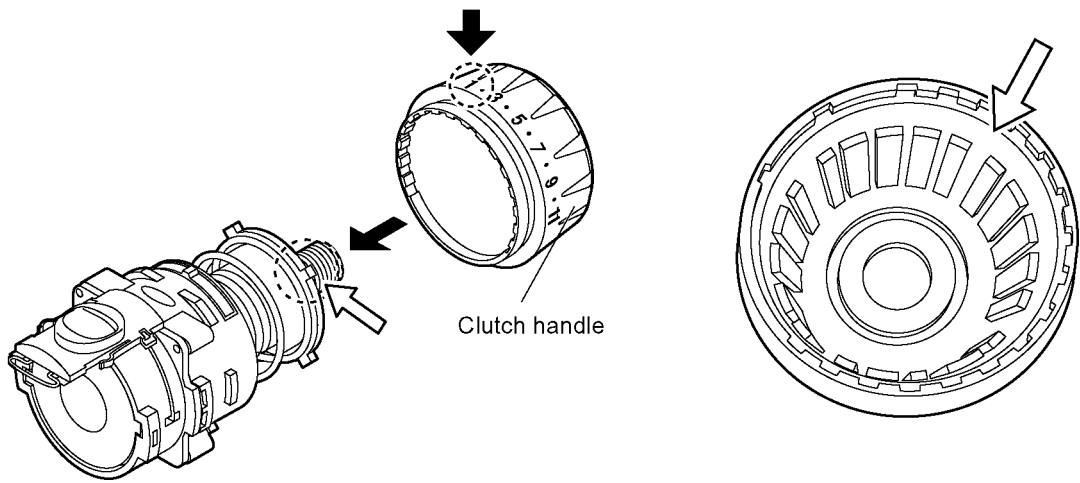
Ref. No. 2D	Procedure 2A → 2B → 2C → 2D	Assembly of the Adjusting Screw and the Clutch Handle.
 <p data-bbox="459 745 528 772">Fig. 14</p>		<p data-bbox="863 197 1516 280">1. Hold the driving block with the click spring on top, and align the smallest projection of adjusting screw with the clutch case. (See Fig. 14)</p> <p data-bbox="863 280 941 302">NOTE:</p> <p data-bbox="901 302 1516 380">Make sure that the adjusting screw has its own correct direction for proper assembly. Failure to do so, the clutch handle does not rotate properly.</p> <p data-bbox="863 380 1516 436">2. Turn the adjusting screw into the driving block about one rotation for clockwise direction.</p> <p data-bbox="863 436 1436 465">3. Set the clutch handle with position 1 on top. (See Fig .15)</p>
 <p data-bbox="790 1294 858 1321">Fig. 15</p>		

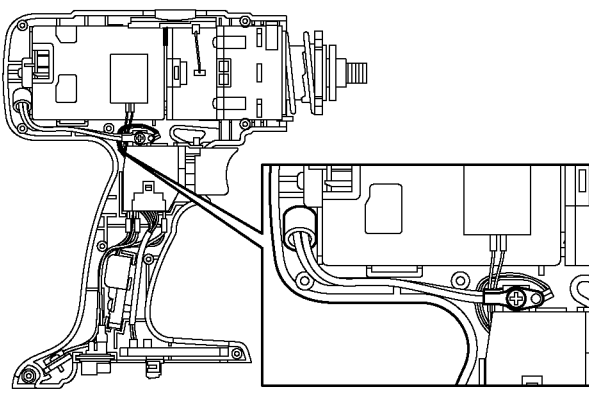
Ref. No. 2E	Procedure 2A → 2B → 2C → 2D → 2E	Assembly of the Switch.
 <p data-bbox="459 1877 528 1904">Fig. 16</p>		<p data-bbox="863 1404 1141 1426">Assembly of the Switch.</p> <p data-bbox="863 1433 1500 1462">1. Press fit the lead wires firmly and set the black lead wire on top.</p> <p data-bbox="863 1462 941 1485">NOTE:</p> <p data-bbox="901 1485 1500 1541">Make sure that the parts of thermistor may not contact housing rib.</p>

5 Wiring Connection Diagram

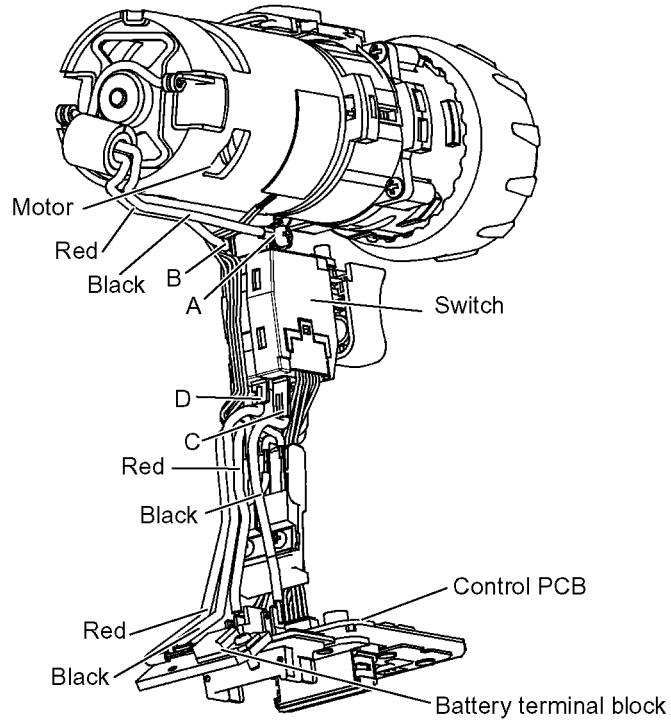

6 Schematic Diagram

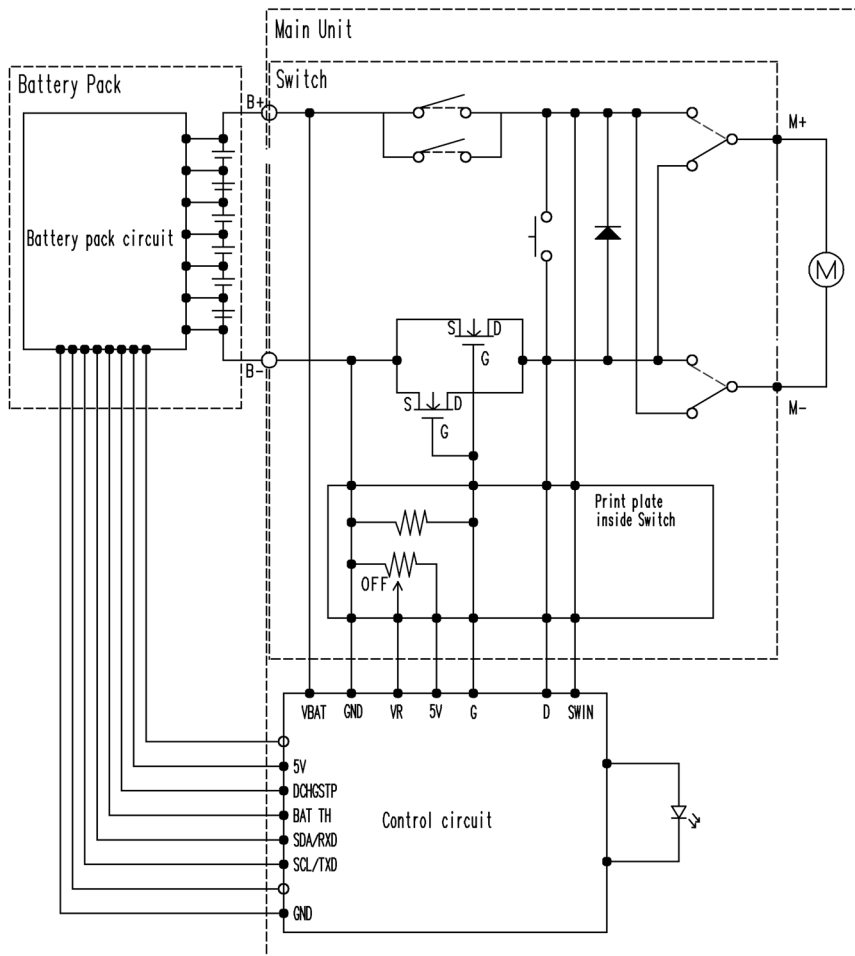

7 Exploded View and Replacement Parts List

Model No. : EY7460 Exploded View for EY7460

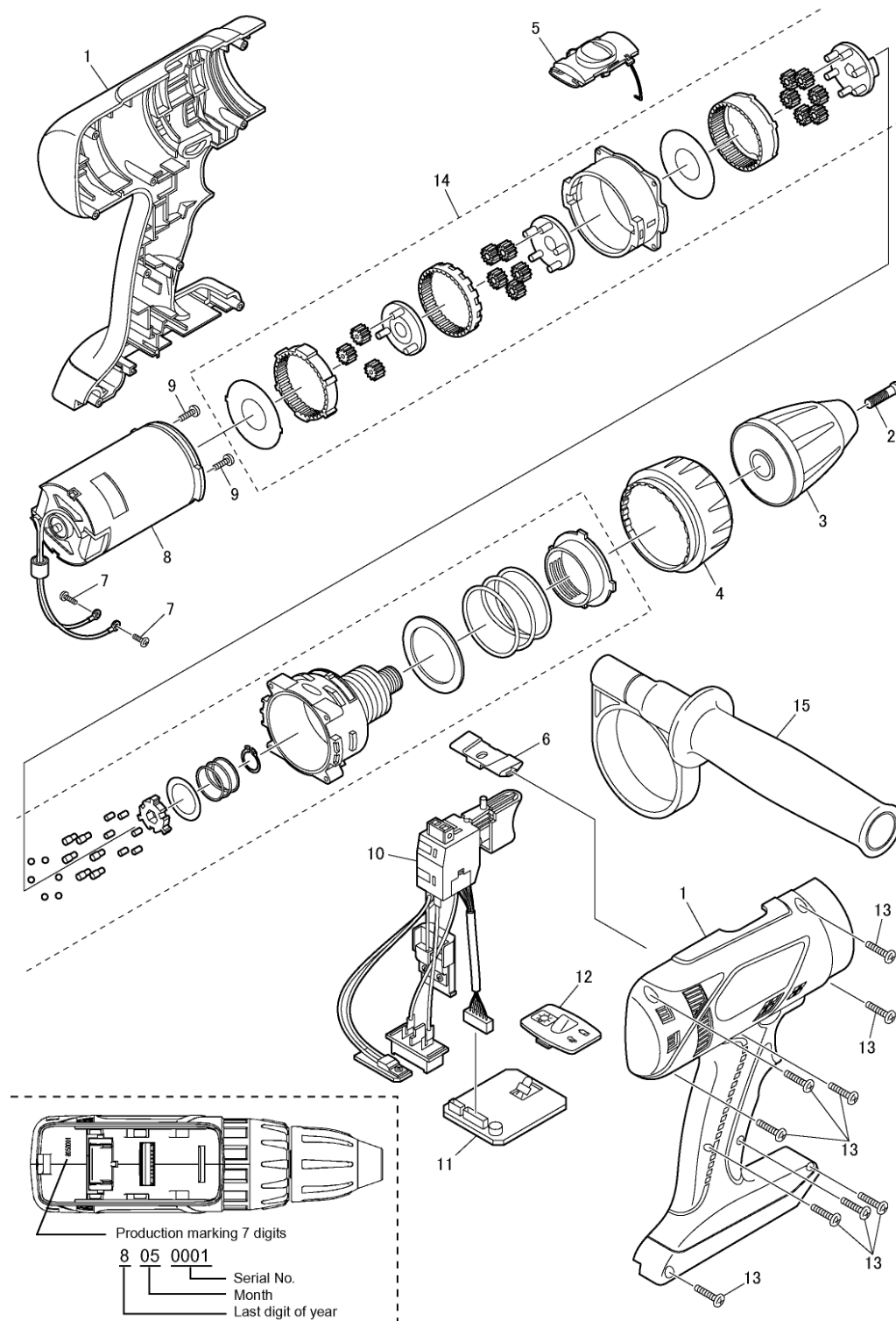

** Battery Pack is available as an optional accessory. See the nearest sales dealer for details.
 *** For replacement parts of charger, see the charger service manual.
 Charger complete set is available as an optional accessory. See the nearest sales dealer for details.

Model No. : EY7460 Parts List

Safety	Ref. No.	Part No.	Part Name & Description	Q'ty	Remarks
EY7460					
	1	WEY7460K3079	HOUSING AB SET	1	(for EUROPE), <SH>
	1	WEY7460K3070	HOUSING AB SET	1	(for OCEANIA), <SH>
	2	WEY6450L6806	CHUCK FASTENING SCREW	1	<SH>
	3	WEY6450K7915	KEYLESS CHUCK	1	<SH>
	4	WEY7460H3228	CLUTCH HANDLE	1	<SH>
	5	WEY7460H3238	H/L CHANGE HANDLE	1	<SH>
	6	WEY7460H3248	F/R SELECTOR HANDLE	1	<SH>
	7	WEY7460S6028	SEMS SCREW	2	(K3*6) <SH>
	8	WEY7460L1009	DC MOTOR	1	<SH>
	9	WEY7460S6038	SEMS SCREW	2	(K5*6) <SH>
	10	WEY7460K2008	SWITCH	1	<SH>
	11	WEY7460L2118	CONTROL PCB	1	<SH>
	12	WEY7460K3958	OPERATION PANEL	1	<SH>
	13	WEY6405K9218	TORX TAPPING SCREW	9	(K3*20) <SH>
	14	WEY7460L1458	GEAR BOX BLOCK	1	<SH>
	15	WEY7460K4628	SUPPORT HANDLE	1	<SH>
	-	WEY9L40R2788	BATTERY PACK COVER	1	<SH>
	-	WEY7460K7018	TOOL CASE	1	<SH>
	-	WEY7460K8109	OPERATING INSTRUCTIONS	1	<SH>

Model No. : EY7960 Exploded View for EY7960

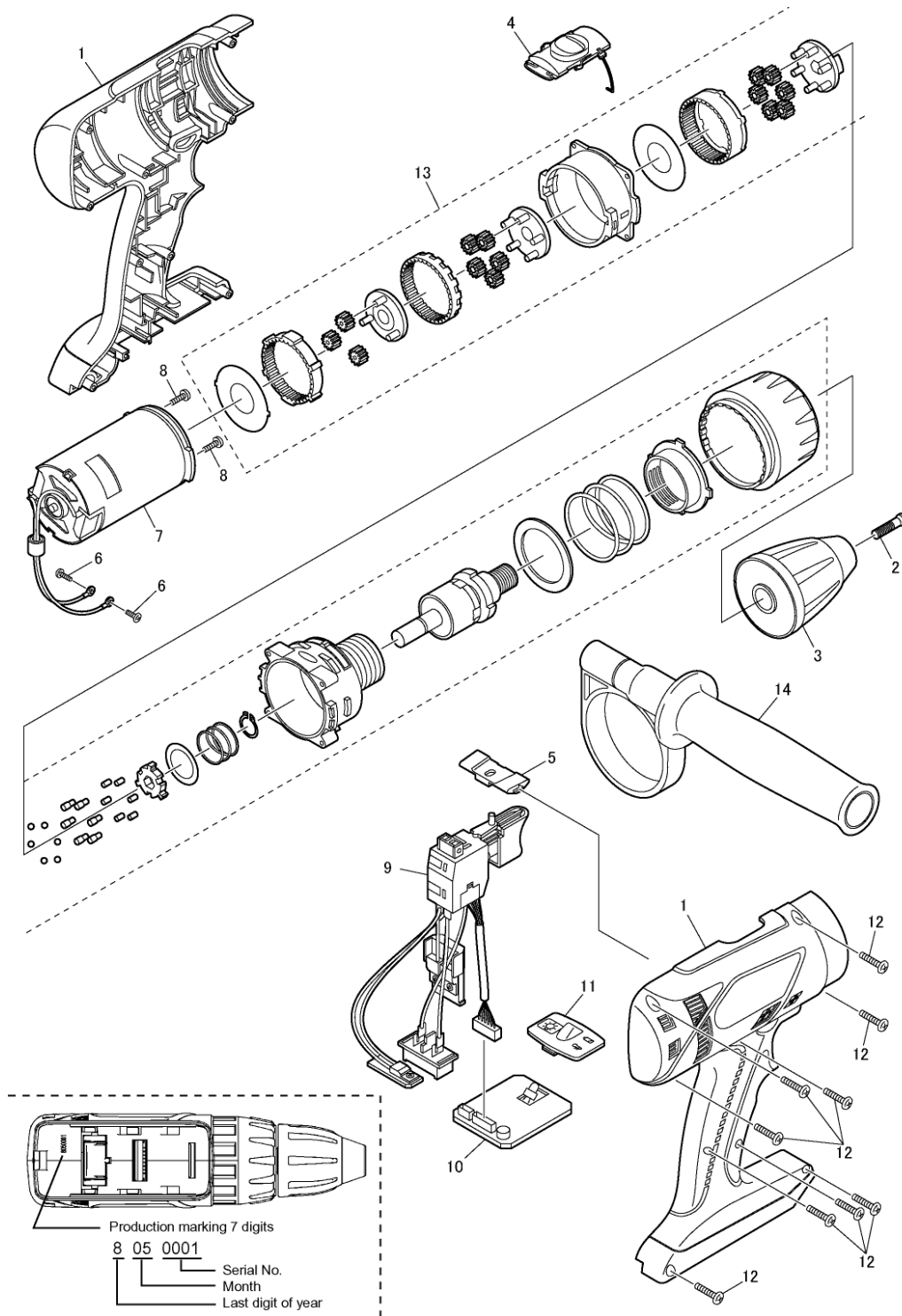

** Battery Pack is available as an optional accessory. See the nearest sales dealer for details.
 *** For replacement parts of charger, see the charger service manual.
 Charger complete set is available as an optional accessory. See the nearest sales dealer for details.

Model No. : EY7960 Parts List

Safety	Ref. No.	Part No.	Part Name & Description	Q'ty	Remarks
EY7960					
	1	WEY7960K3079	HOUSING AB SET	1	(for EUROPE), <SH>
	1	WEY7960K3070	HOUSING AB SET	1	(for OCEANIA), <SH>
	2	WEY6450L6806	CHUCK FASTENING SCREW	1	<SH>
	3	WEY6450K7915	KEYLESS CHUCK	1	<SH>
	4	WEY7460H3238	H/L CHANGE HANDLE	1	<SH>
	5	WEY7460H3248	F/R SELECTOR HANDLE	1	<SH>
	6	WEY7460S6028	SEMS SCREW	2	(K3*6) <SH>
	7	WEY7460L1009	DC MOTOR	1	<SH>
	8	WEY7460S6038	SEMS SCREW	2	(K5*6) <SH>
	9	WEY7460K2008	SWITCH	1	<SH>
	10	WEY7460L2118	CONTROL PCB	1	<SH>
	11	WEY7460K3958	OPERATION PANEL	1	<SH>
	12	WEY6405K9218	TORX TAPPING SCREW	9	(K3*20) <SH>
	13	WEY7960L1458	GEAR BOX BLOCK	1	<SH>
	14	WEY7460K4628	SUPPORT HANDLE	1	<SH>
	-	WEY9L40R2788	BATTERY PACK COVER	1	<SH>
	-	WEY7460K7018	TOOL CASE	1	<SH>
	-	WEY7460K8109	OPERATING INSTRUCTIONS	1	<SH>