

Service Manual

Cordless Drill & Driver / Cordless Hammer Drill & Driver

Model No. **EY7441**

(Cordless Drill & Driver)

Model No. **EY7940**

(Cordless Hammer Drill
& Driver)

Europe and Oceania

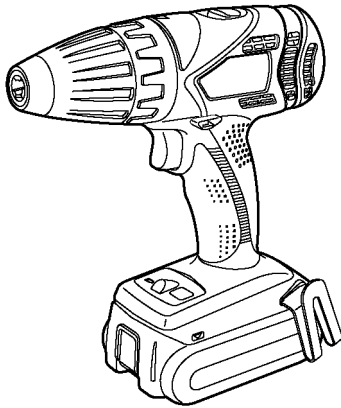

⚠ WARNING

This service information is designed for experienced repair technicians only and is not designed for use by the general public. It does not contain warnings or cautions to advise non-technical individuals of potential dangers in attempting to service a product. Products powered by electricity should be serviced or repaired only by experienced professional technicians. Any attempt to service or repair the product or products dealt with in this service information by anyone else could result in serious injury or death.

IMPORTANT SAFETY NOTICE

There are special components used in this equipment which are important for safety. These parts are marked by ⚠ in the Schematic Diagrams, Circuit Board Diagrams, Exploded Views and Replacement Parts List. It is essential that these critical parts should be replaced with manufacturer's specified parts to prevent shock, fire or other hazards. Do not modify the original design without permission of manufacturer.

TABLE OF CONTENTS

	PAGE	PAGE
1 Warning-----	2	
2 Specifications -----	2	
3 Troubleshooting Guide-----	3	
4 Disassembly and Assembly Instructions -----	7	
5 Wiring Connection Diagram -----	15	
6 Schematic Diagram-----	15	
7 Exploded View and Replacement Parts List -----	16	

Panasonic

© Panasonic Electric Works Co., Ltd. 2010.
All rights reserved. Unauthorized copying and distribution is a violation of law.

1 Warning

Caution:

- Pb free solder has a higher melting point than standard solder; Typically the melting point is 50 - 70°F (30 - 40°C) higher. Please use a soldering iron with temperature control and adjust it to 750 ± 20°F (400 ± 10°C). In case of using high temperature soldering iron, please be careful not to heat too long.
- Pb free solder will tend to splash when heated too high (about 1100°F / 600°C).

2 Specifications

2.1. EY7441 MAIN UNIT

Motor	14.4V DC	
No load speed	LOW	70 ~ 400/min (rpm)
	HIGH	200 ~ 1400/min (rpm)
Chuck capacity	φ 1.5 ~ 13mm (1/16" ~ 1/2")	
Maximum torque	31.9N·m Stalling torque (3.1Ah Li-ion Battery)	
	28.7N·m Stalling torque (1.5Ah Li-ion Battery)	
Clutch torque	Approx. 0.5Nm (5.0kgf-cm, 4.3in-lbs) – 4.4Nm (45.0kgf-cm, 39.0in-lbs)	
Overall length	193mm (7-5/8")	
Weight (with battery pack EY9L41)	1.7kg (3.75lbs)	

2.2. EY7940 MAIN UNIT

Motor	14.4V DC	
No load speed	LOW	70 ~ 400/min (rpm)
	HIGH	200 ~ 1400/min (rpm)
Chuck capacity	φ 1.5 ~ 13mm (1/16" ~ 1/2")	
Blows rate per minute	LOW	1260-7200 min ⁻¹ (bpm)
	HIGH	3600-25200 min ⁻¹ (bpm)
Clutch torque	Approx. 1.0Nm (10.0kgf-cm, 8.7in-lbs) – 4.4Nm (45.0kgf-cm, 37.0in-lbs)	
Overall length	200mm (7-7/8")	
Weight (with battery pack EY9L41)	1.75kg (3.86lbs)	

2.3. MAXIMUM RECOMMENDED CAPACITIES

Model		EY7441	EY7940
Screw driving	Machine screw	M5	
	Wood screw	Ø 6.8 mm (17/64")	
	Self-drilling screw	Ø 6 mm (15/64")	
Drilling	for Wood	Ø 38 mm (1-3/8")	
	for Metal	Ø 13 mm (1/2")	
	for Masonry	-----	13 mm (1/2")

3 Troubleshooting Guide

(Refer to Wiring Connection Diagram)

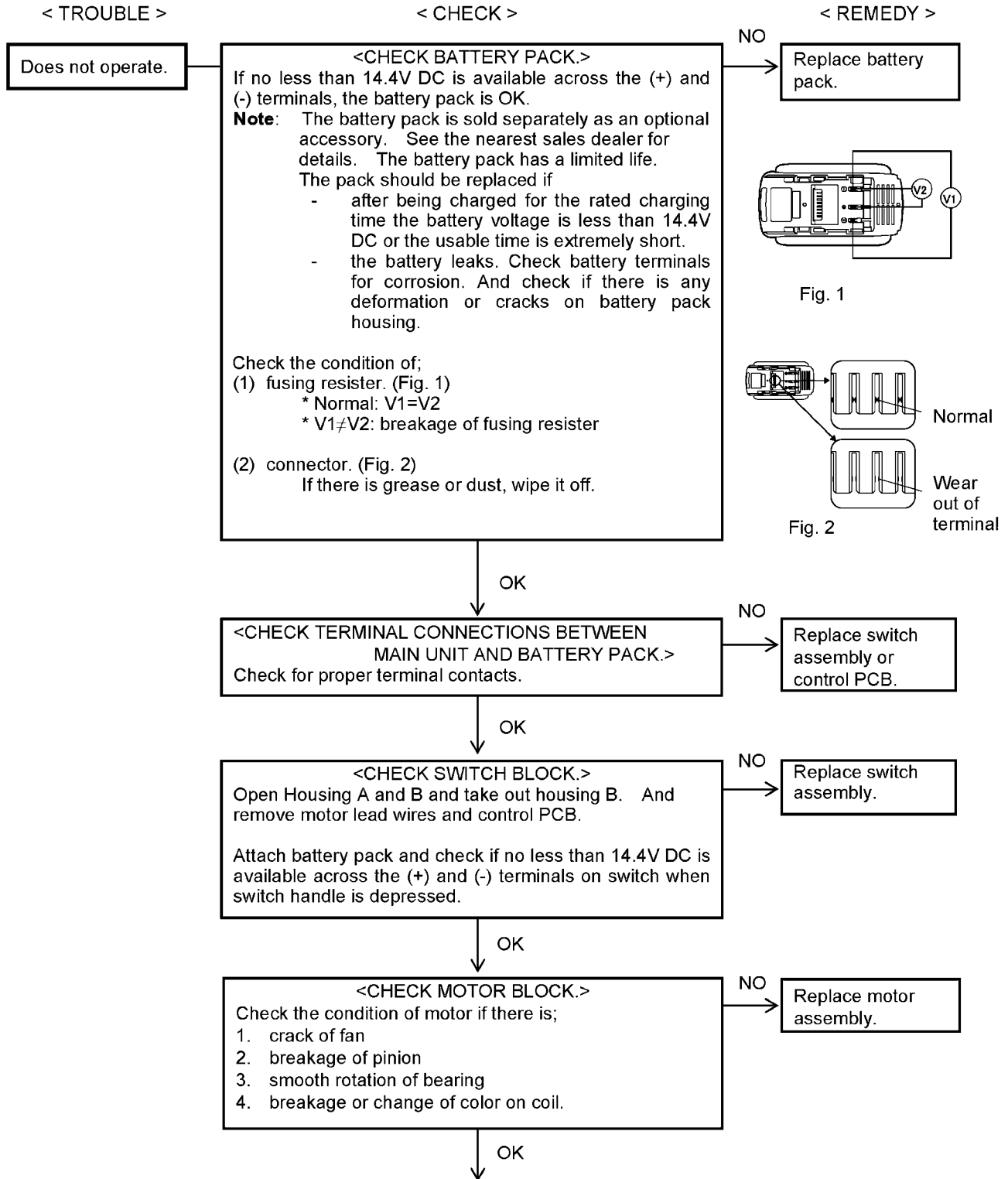

< TROUBLE >

< CHECK >

< REMEDY >

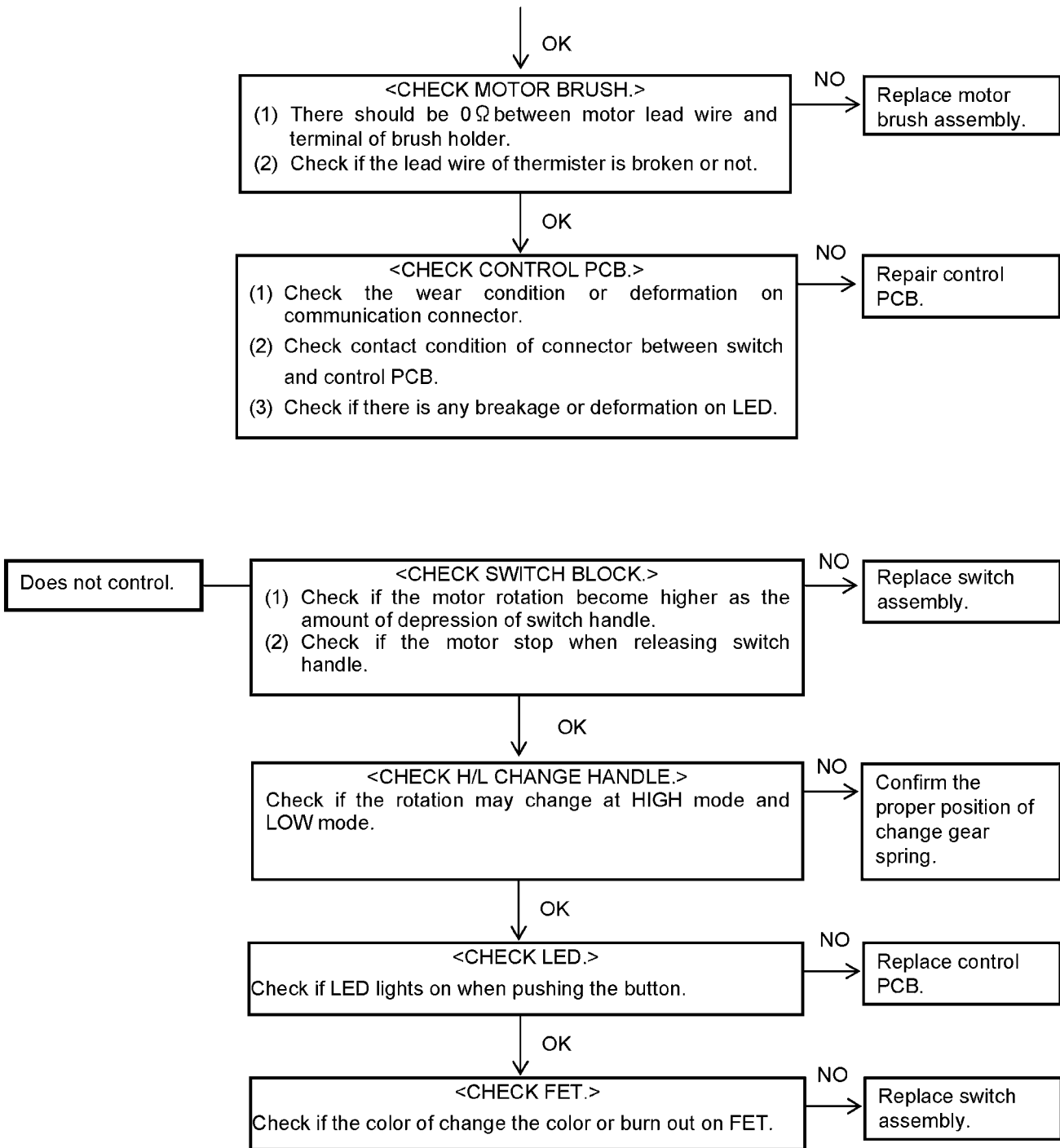

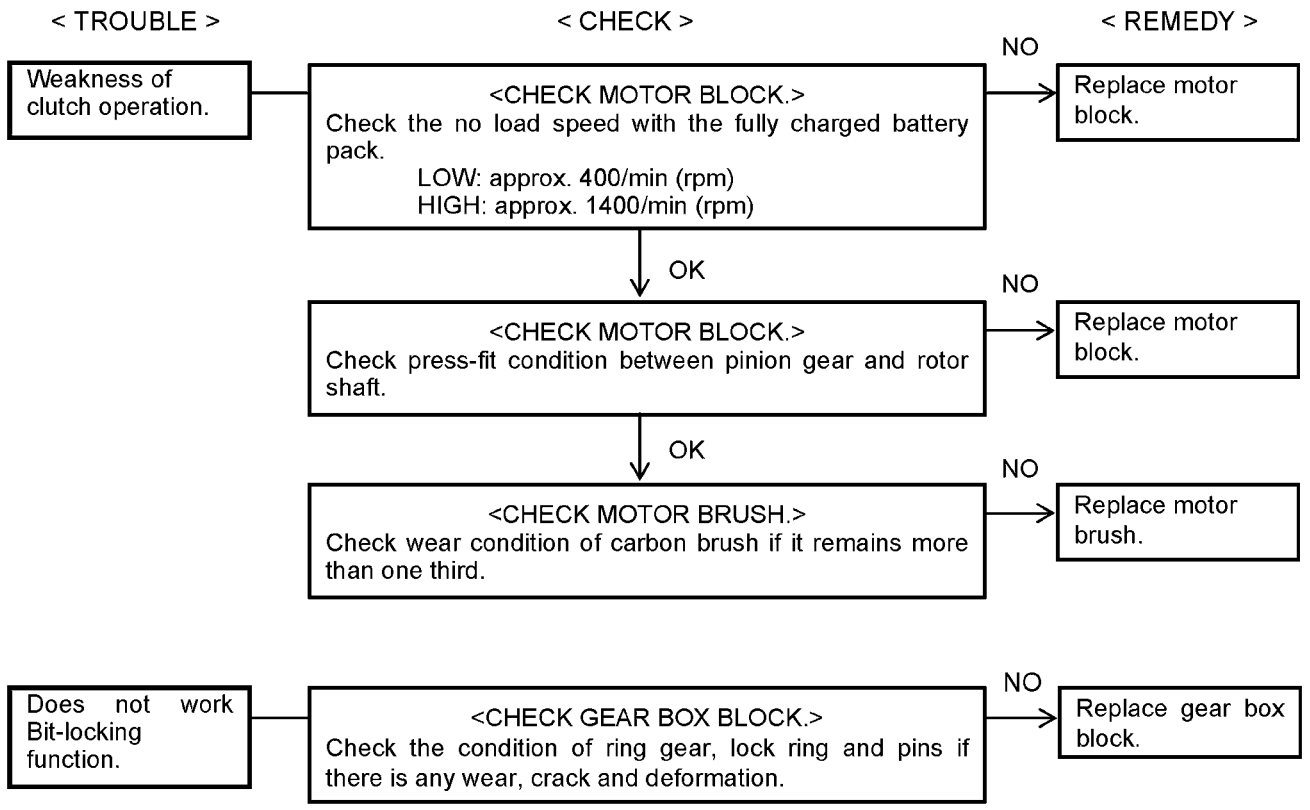

for EY7940 only

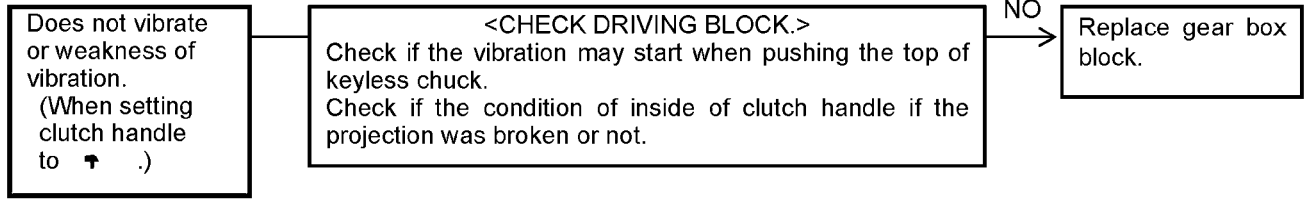

3.1. Trial Operation (after checking Troubleshooting Guide.)

3.1.1. ASSEMBLY

1. Confirm if there is NO gap between Housing A and B by pinching the lead wires.
2. Confirm all screws are tightened firmly.
3. There should be no abnormal sound when shaking the unit.
4. There is no dust or deformation on battery terminals.
5. Confirm if there is no dirt when repairing.

3.1.2. OPERATION

1. Confirm the forward and reverse side of rotation.
2. Confirm if LED lights ON. Once battery pack is removed, press the switch handle; otherwise LED does not light ON.
3. Confirm if the tools may not become hot in a short operation.
4. Confirm the action when setting the DRILL mode.
5. Confirm if the chuck jaws move smoothly and hold the bit firmly.

only for EY7940

6. Confirm no vibration on reverse side.

3.1.3. SWITCH

1. Confirm the rotation of speed if it changes between 200-1400 \pm 140 rpm in proportion to the amount of pushing level on switch handle on HIGH mode and 70-400 \pm 40 rpm on LOW mode.
2. Confirm if the rotation stops when releasing the switch handle.



3.1.4. CLUTCH

1. Check if the clutch torque changes suited for the number of clutch.

4 Disassembly and Assembly Instructions

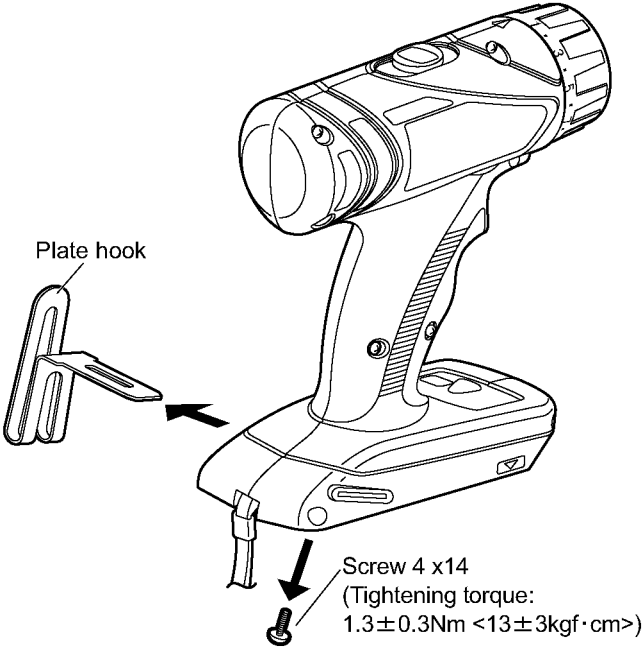
4.1. How to disassemble Plate hoot and Keyless chuck.

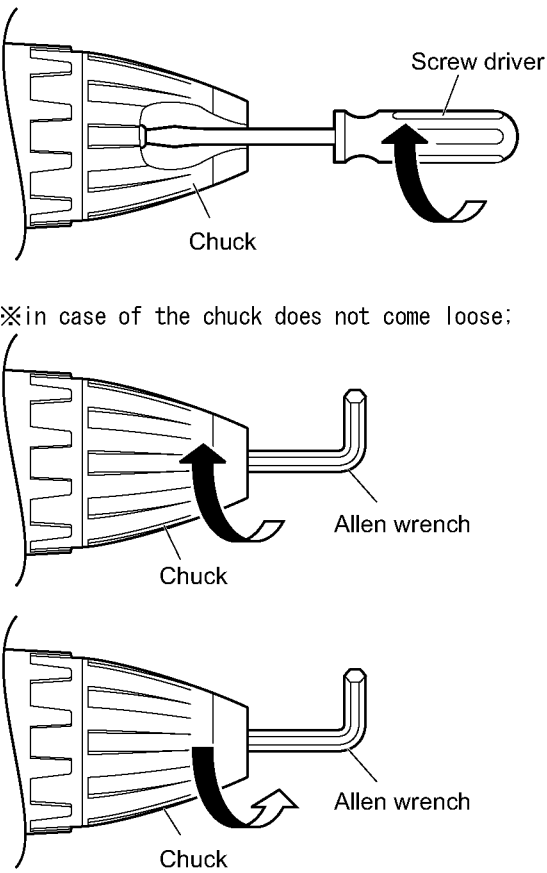
Ref. No. 1A	Procedure 1A	Removal of Plate hook.
		<p>(Removal)</p> <ol style="list-style-type: none"> 1. Loosen a screw. 2. Take out the plate hook.

Ref. No. 2A	Procedure 2A	Removal of the Housing.
 <p>※in case of the chuck does not come loose;</p>		<p>NOTE: When attaching or removing a bit, disconnect battery pack from tool.</p> <ol style="list-style-type: none"> 1. Set the clutch handle to position  and select "LOW" position. 2. Turn the lock collar counterclockwise (looking from the front) to open the chuck jaws. 3. Use a screwdriver to turn the chuck fastening screw inside the chuck clockwise direction of the arrow, and remove the screw. <p>NOTE: If the chuck fastening screw will not come loose, insert the allen wrench into the chuck and lightly tap in the clockwise direction with a hammer to tighten the chuck, and then loosen the chuck fastening screw.</p> <ol style="list-style-type: none"> 4. Insert the allen wrench into the chuck, and turn counterclockwise direction in the arrow with holding the unit by the vise to remove the chuck.

4.2. How to disassemble Main unit.

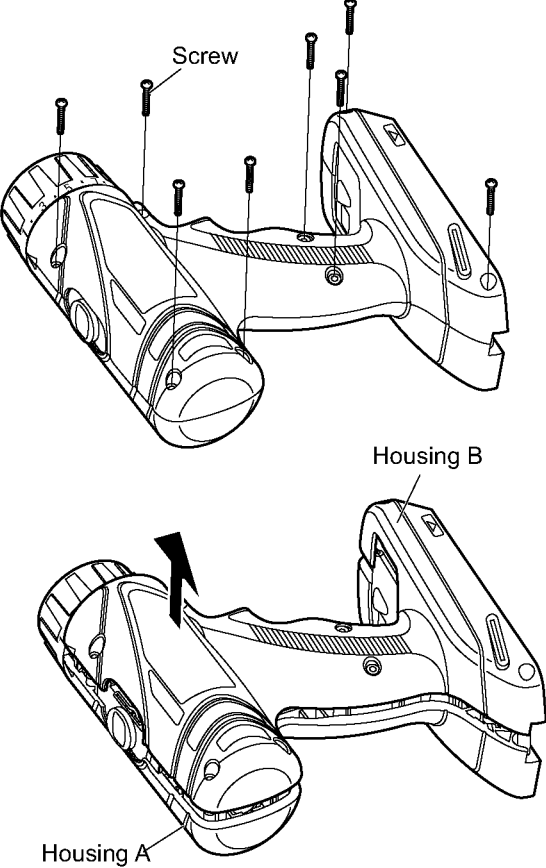
Ref. No. 3A	Procedure 3A	Removal of the Housing.
 <p data-bbox="347 318 418 340">Screw</p> <p data-bbox="545 712 657 734">Housing B</p> <p data-bbox="210 1115 322 1137">Housing A</p>		<p data-bbox="817 250 1088 273">1. Remove 8 housing screws.</p>

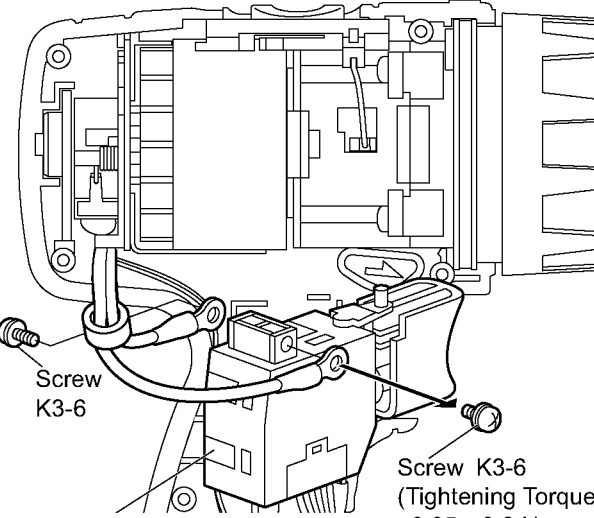
Ref. No. 3B	Procedure 3A → 3B	Removal of Motor screw.
 <p data-bbox="178 1787 242 1832">Screw K3-6</p> <p data-bbox="146 1930 322 1953">Switch assembly</p> <p data-bbox="539 1877 737 1989">Screw K3-6 (Tightening Torque : 0.85 ± 0.2 Nm <8.7 ± 2kgf·cm>)</p>		<p data-bbox="817 1393 912 1415">(Removal)</p> <p data-bbox="817 1415 1008 1438">1. Remove 2 screws.</p>

Ref. No. 3C

Procedure 3A → 3B → 3C

Removal of Switch and Driving block.

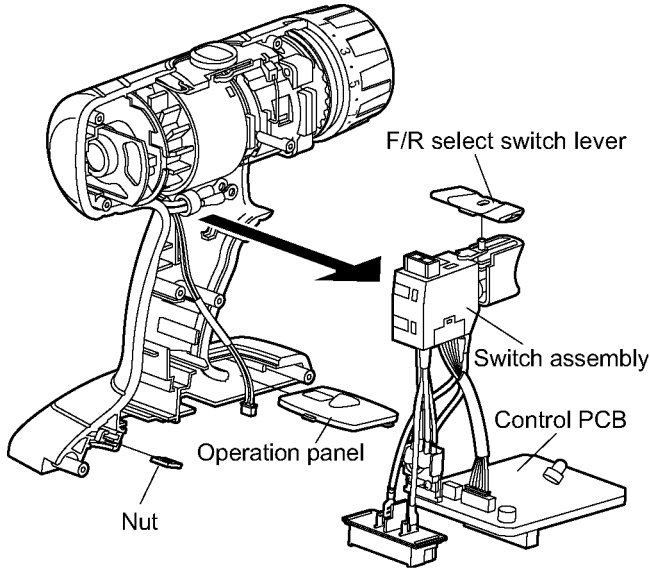

(Removal)

1. Take out the switch assembly.
2. Take out the driving block.
3. Separate the motor from the gear box block by twisting the motor to unlock tabs.

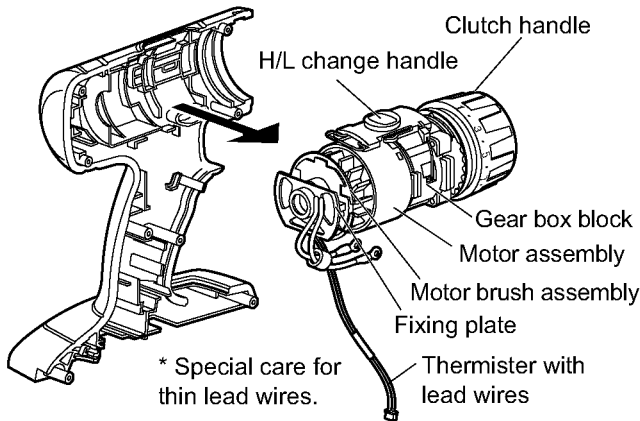
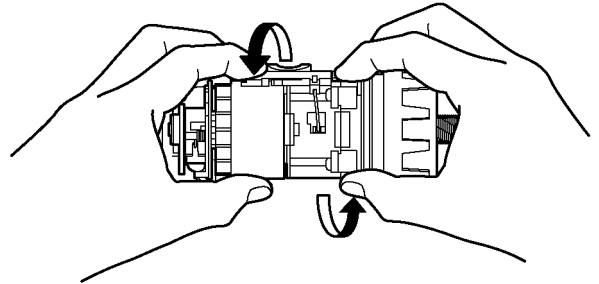

Ref. No. 3D

Procedure 3A → 3B → 3C → 3D

Removal or assembly of Control PCB.

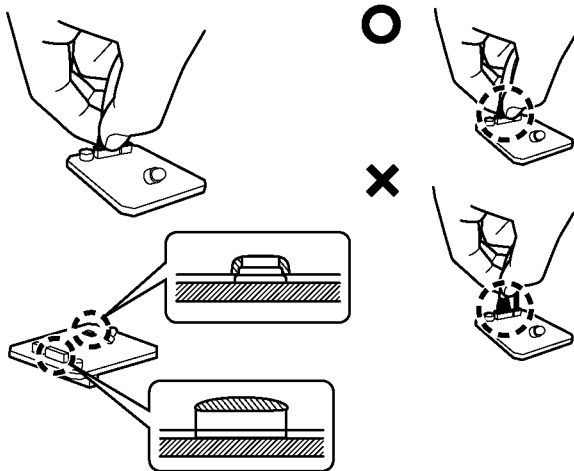

(Removal)

1. Take out the connector from the control PCB.

NOTE:

Make sure hold the connector at the bottom area.

(Assembly)

1. Apply the grease around the tact switch.
2. Insert the connector.

Ref. No. 3E	Procedure 3A → 3B → 3C → 3D → 3E	Removal or attachment of the Gear Box Block.
<p>for EY7441</p>		<p>(Removal)</p> <ol style="list-style-type: none"> 1. Turn the thrust plate to remove. 2. The internal parts of gear box block can be removed one after another. <p>(Attachment)</p> <ol style="list-style-type: none"> 1. Start from inserting 6 pins into the driving block as shown in the figure. 2. Assemble the other parts in reverse order as shown in the figure. <p>NOTE: Carriers and Ring Gears have their own correct directions for proper reassembly.</p>
<p>for EY7940</p>		

Assembly of the Adjusting Screw and the Clutch Handle for EY7441

1. Hold the driving block with the click spring on top, and align the narrow projection of adjusting screw with 45° right side of the clutch case.

NOTE:

- Make sure that the adjusting screw has its own correct direction for proper assembly. Failure to do so, the clutch handle does not rotate properly.
- 2. Turn the adjusting screw into the driving block about one rotation for clockwise direction.
- 3. Set the clutch handle with position 1 on top. (Align the position 1 of clutch handle with the narrow projection of driving block.)
- 4. Insert the clutch handle with adjusting the tabs of adjusting screw to the groove of inside clutch handle.

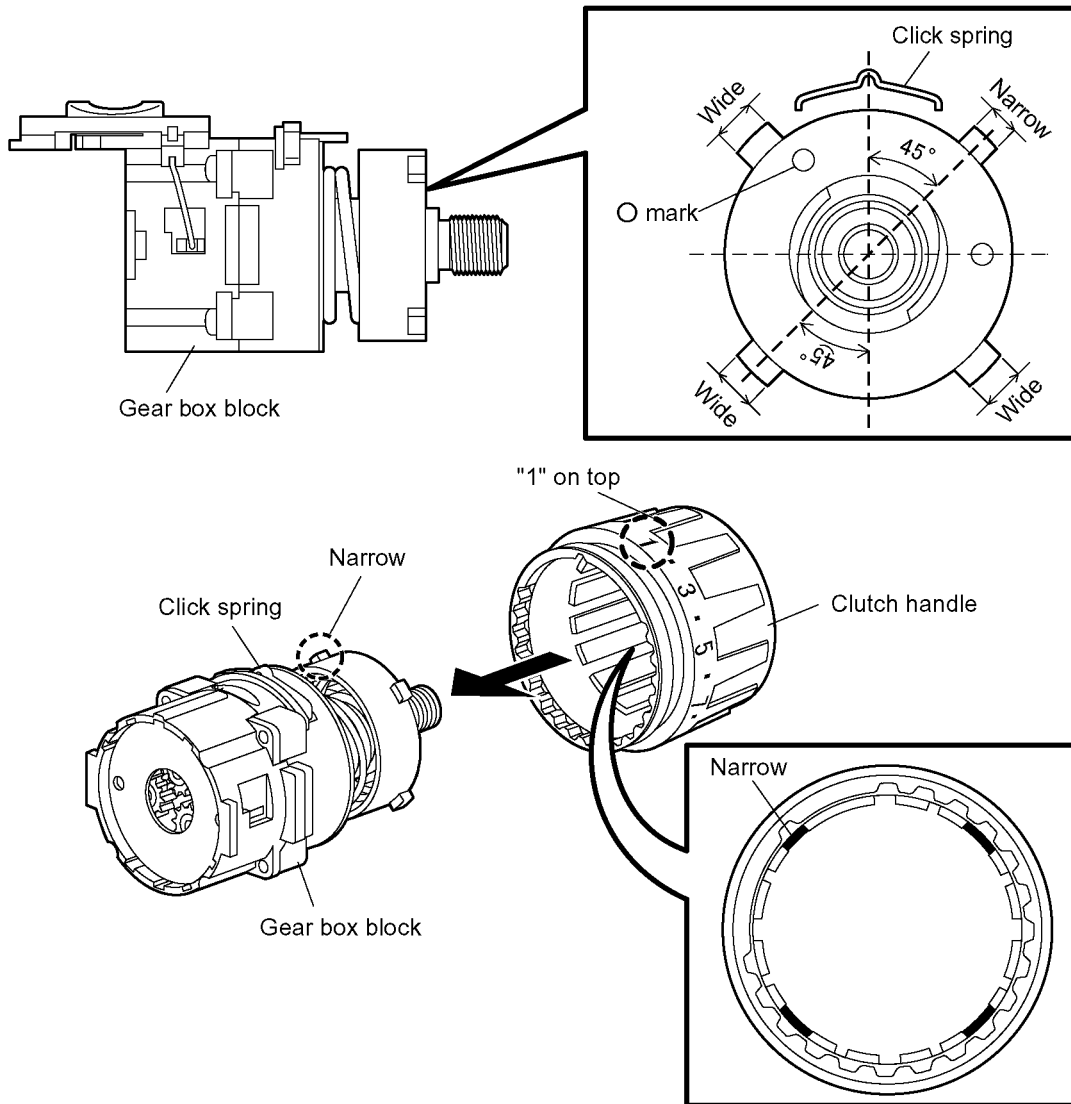

Ref. No. 3F	Procedure 3A → 3B → 3C → 3D → 3E → 3F	Assembly of the Adjusting Screw and the Clutch Handle. for EY7940
		<ol style="list-style-type: none"> 1. Hold the driving block with the click spring on top, and align the Δ mark of adjusting screw with the bottom of the clutch case. <p>NOTE: Make sure that the adjusting screw has its own correct direction for proper assembly. Failure to do so, the clutch handle does not rotate properly.</p> <ol style="list-style-type: none"> 2. Turn the adjusting screw into the driving block about one rotation for clockwise direction. 3. Turn the adjusting screw into the driving block about one rotation for clockwise direction. (Align the projection of clutch handle on bottom.)

Ref. No. 3G	Procedure 3A → 3B → 3C → 3D → 3E → 3F → 3G	Attachment of the H/L change handle.
		<ol style="list-style-type: none"> 1. Insert the both side of handle spring into the groove of Ring gear A.

for EY7441

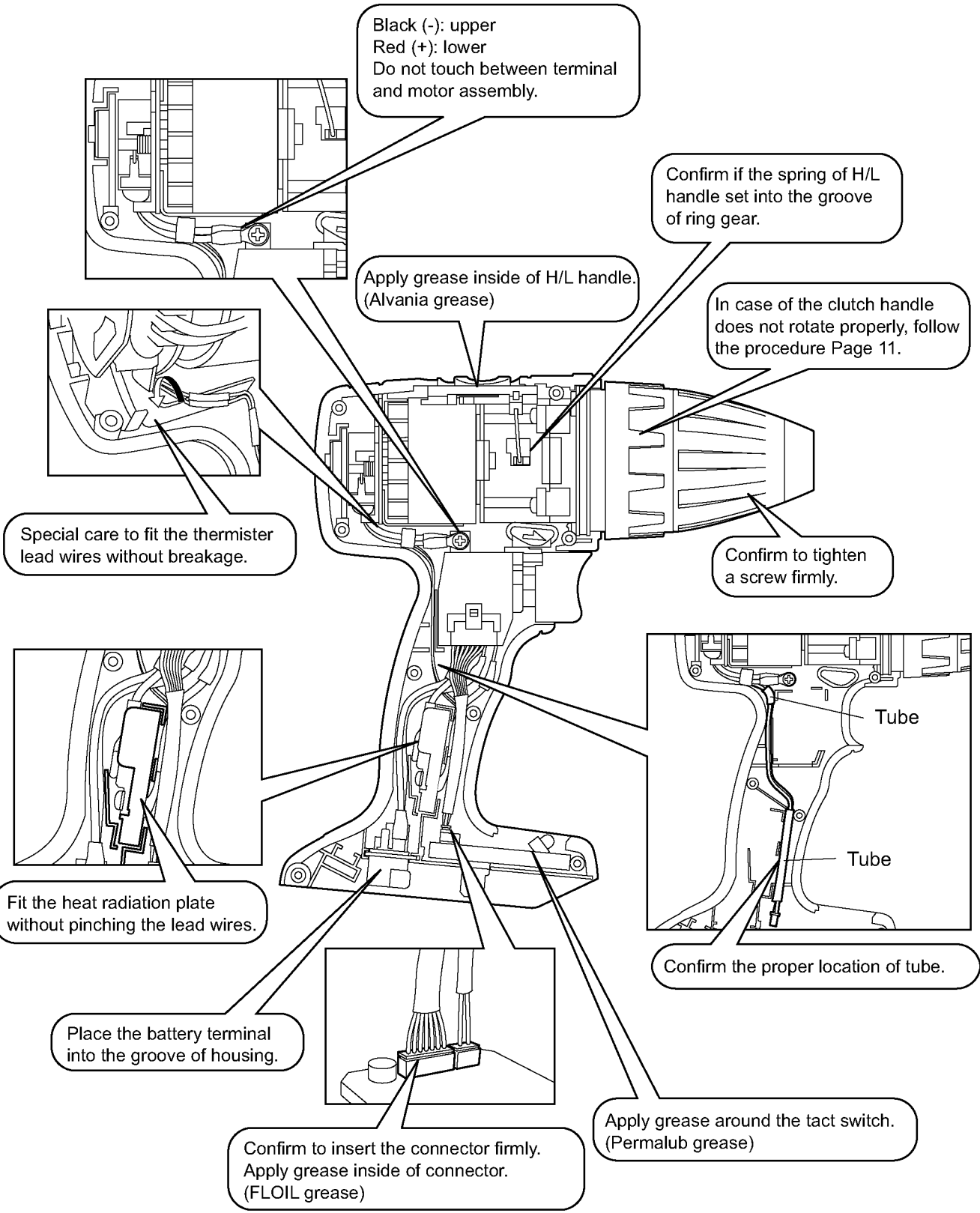

for EY7940

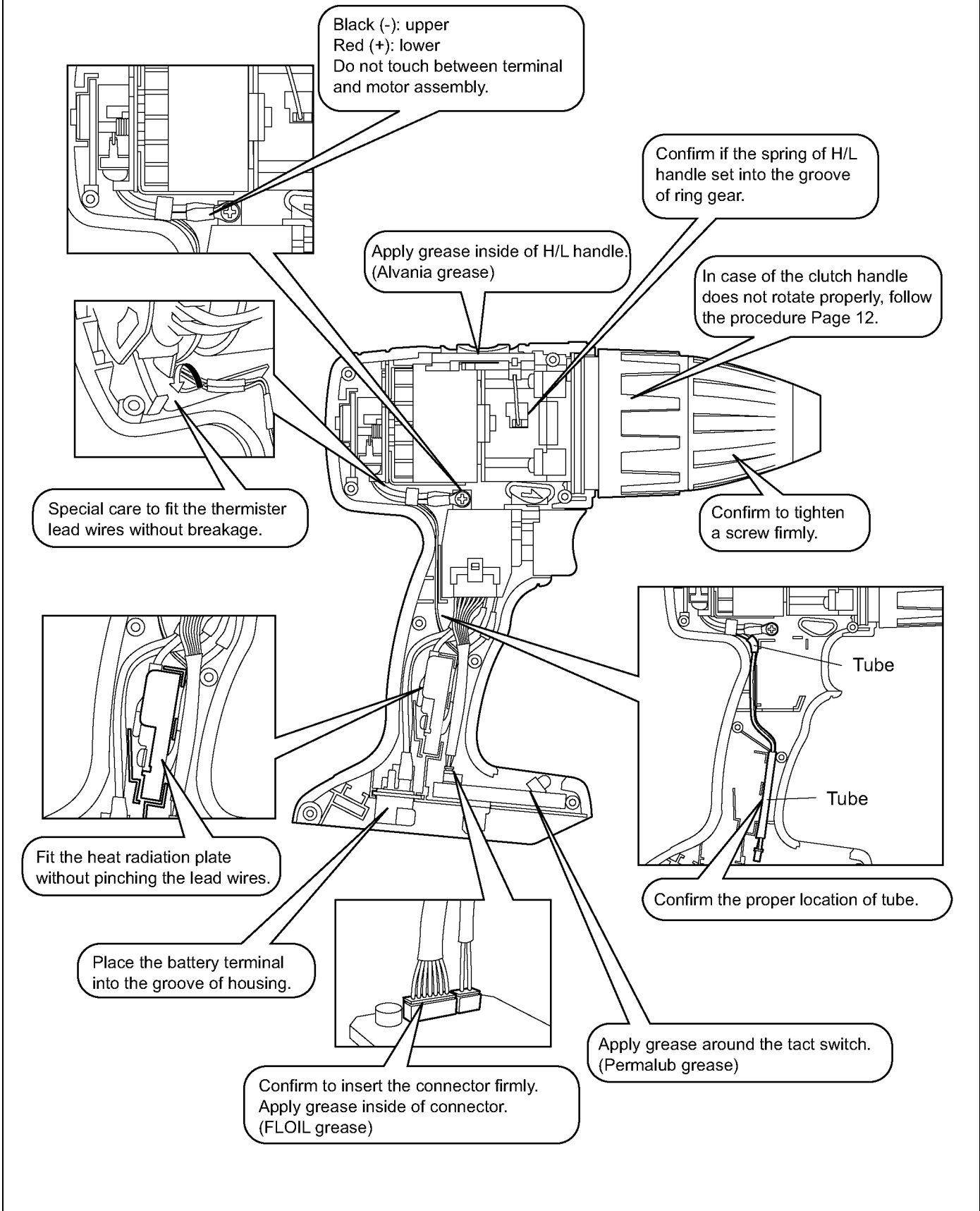

5 Wiring Connection Diagram

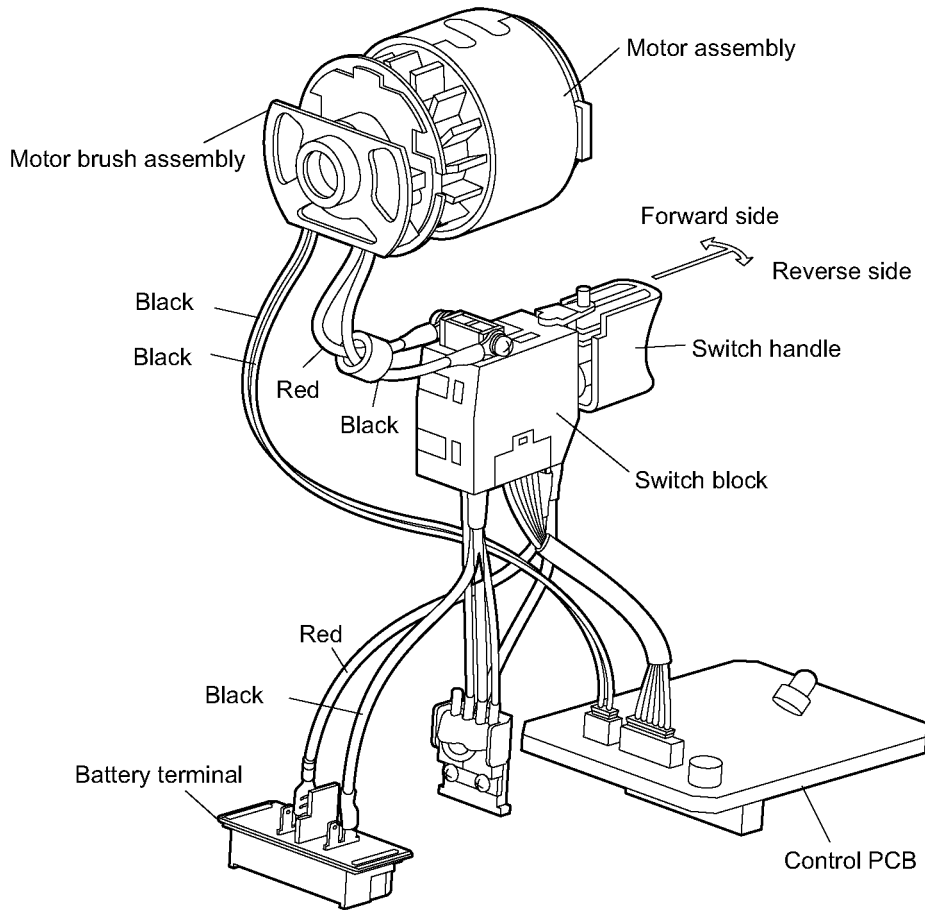

6 Schematic Diagram

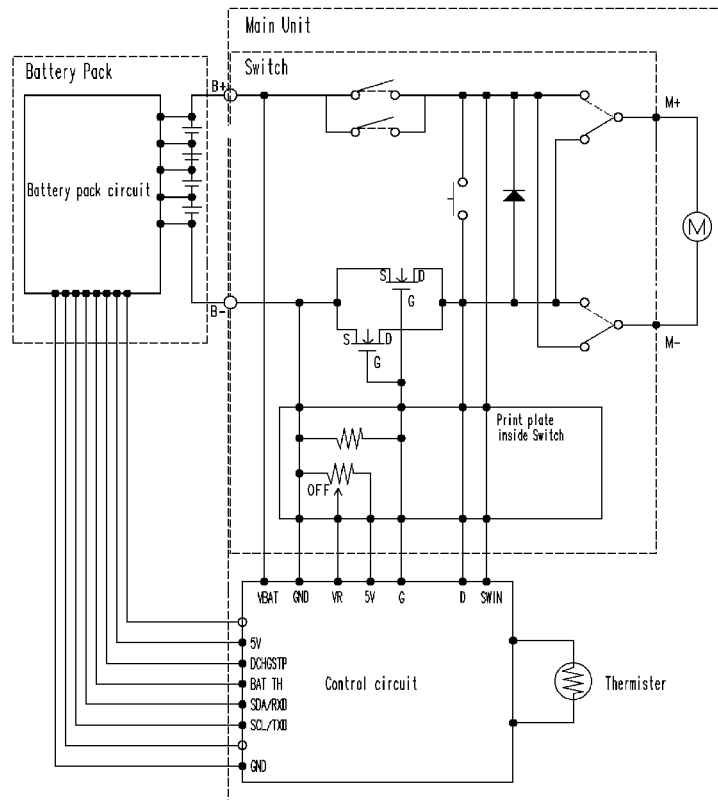

7 Exploded View and Replacement Parts List

Model No. : EY7441 Exploded View for EY7441

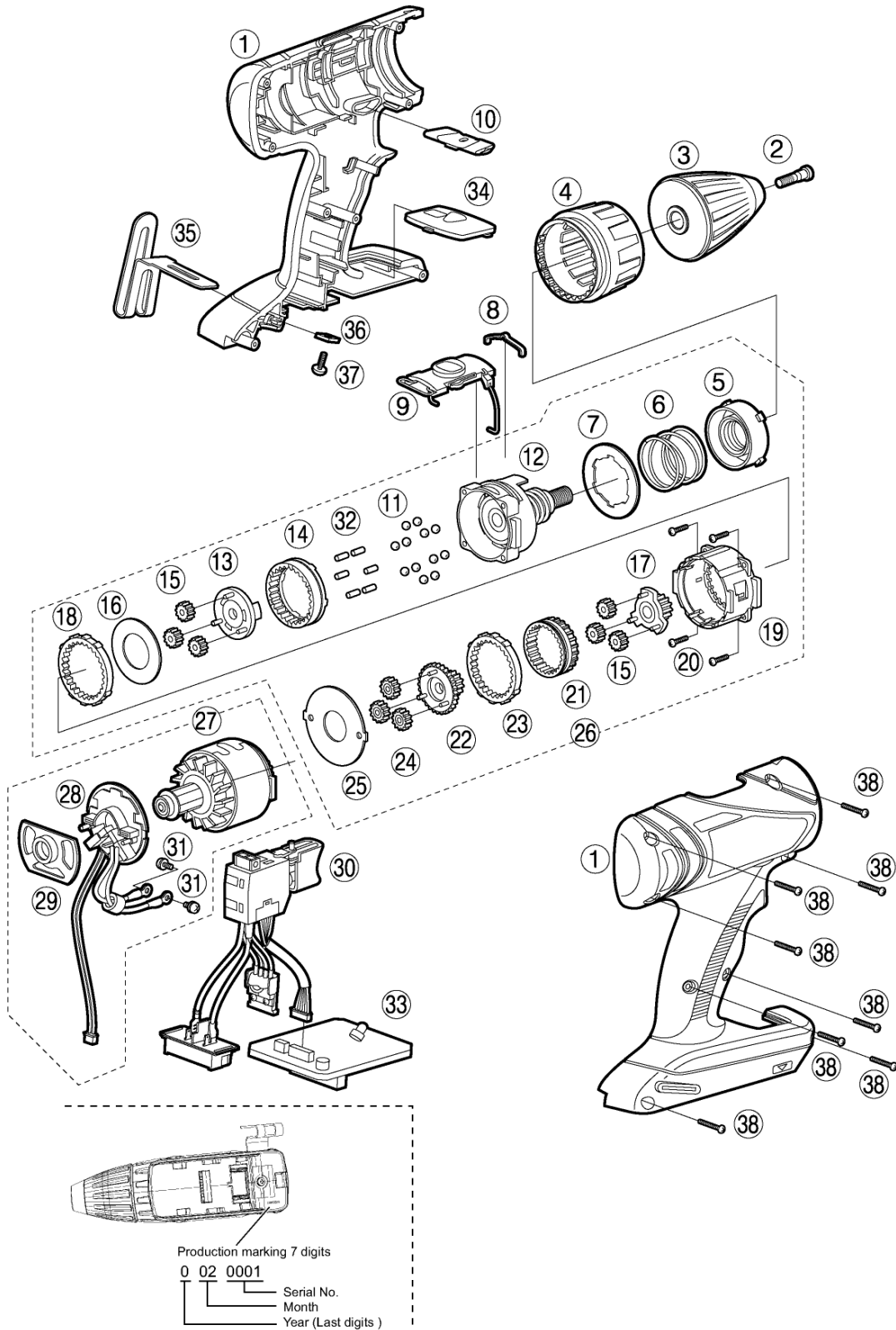

Model No. : EY7441 Parts List

Safety	Ref. No.	Part No.	Part Name & Description	Q'ty	Remarks
EY7441					
	1	WEY7441K3079	HOUSING AB SET	1	(for EUROPE)
	1	WEY7441K3070	HOUSING AB SET	1	(for OCEANIA)
	2	WEY6450L6806	CHUCK FASTENING SCREW	1	
	3	WEY7441K7917	KEYLESS CHUCK	1	
	4	WEY7441H3227	CLUTCH HANDLE	1	
	5	WEY7441L0637	ADJUSTING SCREW	1	
	6	WEY7441L0177	CLUTCH SPRING	1	
	7	WEY7441L0577	CLUTCH PLATE	1	
	8	WEYT107L0457	CLICK SPRING A	1	
	9	WEY7460H3237	H/L CHANGE HANDLE	1	
	10	WEY7460H3248	F/R SELECTOR HANDLE	1	
	11	WEY7441L6968	STEEL BALL	12	($\phi 5$), (12PCS/PK)
	12	WEY7441L1088	DRIVING BLOCK	1	
	13	WEY7441L1138	CARRIER	1	
	14	WEY7441L1428	RING GEAR	1	
	15	WEY7441L1348	PLANET GEAR	6	(3PCS/PK)
	16	WEY7441L0858	THRUST PLATE	1	($\phi 37.95$)
	17	WEY7441L1118	CARRIER	1	
	18	WEY7441L0268	STOPPER	1	
	19	WEY7441L1768	GEAR CASE	1	
	20	WEY7441K9628	TAPPING SCREW	4	(K3-12)
	21	WEY7441L1458	RING GEAR A	1	
	22	WEY7441L1128	CARRIER B	1	
	23	WEY7441L1468	RING GEAR B	1	
	24	WEY7441L1368	PLANET GEAR B	3	(3PCS/PK)
	25	WEY7441L0888	THRUST PLATE	1	$\phi 37.8$
	26	WEY7441L4057	GEAR BOX BLOCK	1	
	27	WEY7441L1008	MOTOR ASSEMBLY	1	
	28	WEY7441L2578	MOTOR BRUSH ASSEMBLY	1	
	29	WEY7441L0127	FIXING PLATE	1	
	30	WEY7441L2007	SWITCH ASSEMBLY	1	
	31	WEY7441L6028	SCREW	2	(K3-6)
	32	WEY7441L0378	ROLLER SET	6	($\phi 3.175 \times 7.2$), (6PCS/PK)
	33	WEY7441L2117	CONTROL PCB	1	
	34	WEY7460K3958	OPERATION PANEL	1	
	35	WEY7543K3187	PLATE HOOK	1	
	36	WEY7441L6487	NUT	1	(M4)
	37	WEY7441K6217	SCREW	1	(4-14)
	38	WEY7441K9038	TAPPING SCREW	8	(K3-20)
	-	WEY9633K7010	TOOL CASE	1	
	-	WEY7441K8109	OPERATING INSTRUCTIONS	1	

Model No. : EY7940 Exploded View for EY7940

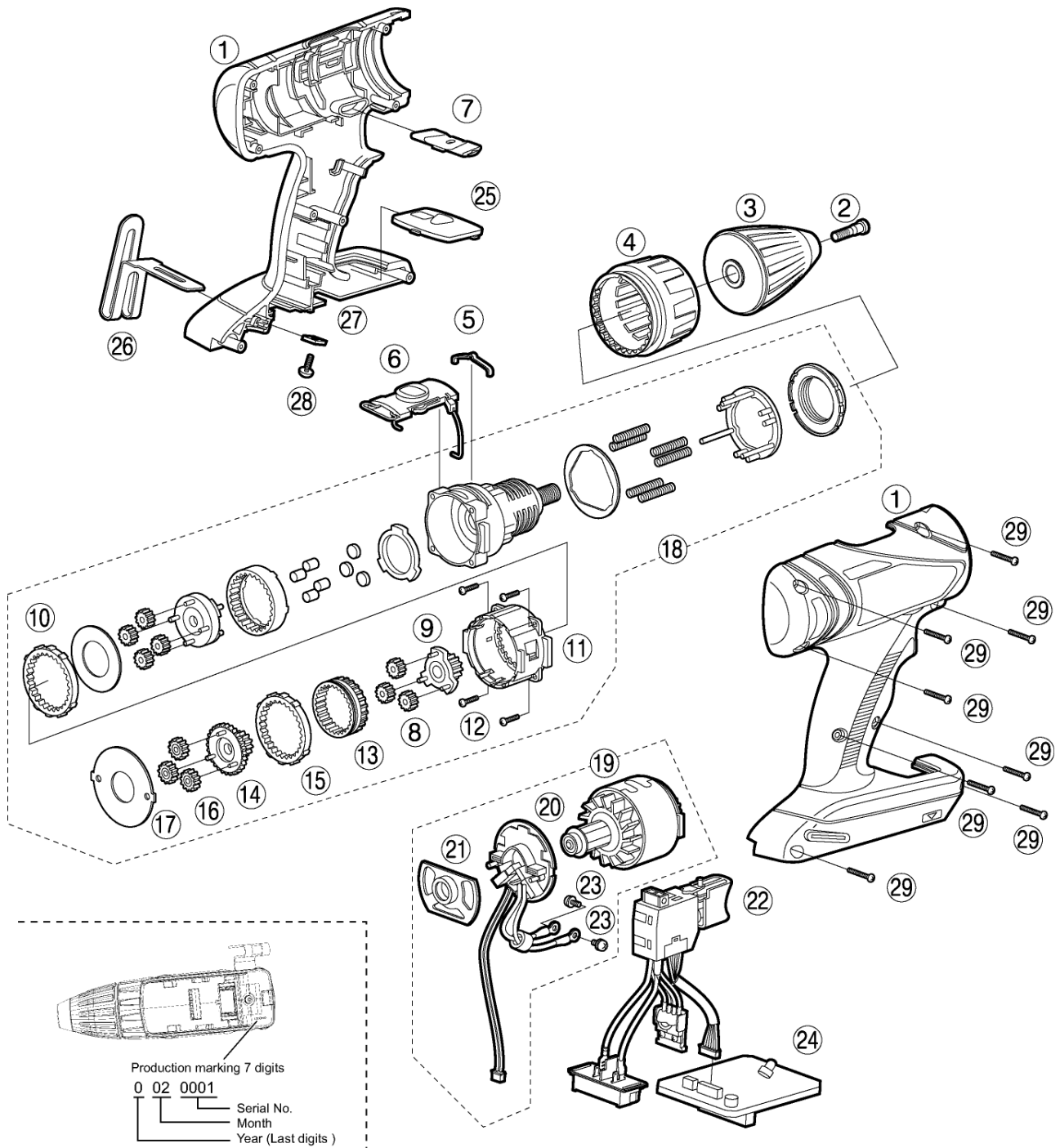

Model No. : EY7940 Parts List

Safety	Ref. No.	Part No.	Part Name & Description	Q'ty	Remarks
EY7940					
	1	WEY7940K3079	HOUSING AB SET	1	(for EUROPE)
	1	WEY7940K3070	HOUSING AB SET	1	(for OCEANIA)
	2	WEY6450L6806	CHUCK FASTENING SCREW	1	
	3	WEY7441K7917	KEYLESS CHUCK	1	
	4	WEY7940K3227	CLUTCH HANDLE	1	
	5	WEYT107L0457	CLICK SPRING A	1	
	6	WEY7460H3237	H/L CHANGE HANDLE	1	
	7	WEY7460H3248	F/R SELECTOR HANDLE	1	
	8	WEY7441L1348	PLANET GEAR	6	(3PCS/PK)
	9	WEY7441L1118	CARRIER	1	
	10	WEY7441L0268	STOPPER	1	
	11	WEY7441L1768	GEAR CASE	1	
	12	WEY7940K9628	TAPPING SCREW	4	(K3-12)
	13	WEY7441L1458	RING GEAR A	1	
	14	WEY7441L1128	CARRIER B	1	
	15	WEY7441L1468	RING GEAR B	1	
	16	WEY7940L1368	PLANET GEAR B	3	(3PCS/PK)
	17	WEY7441L0888	THRUST PLATE	1	(φ37.8)
	18	WEY7940L4057	GEAR BOX BLOCK	1	
	19	WEY7441L1008	MOTOR ASSEMBLY	1	
	20	WEY7441L2578	MOTOR BRUSH ASSEMBLY	1	
	21	WEY7441L0127	FIXING PLATE	1	
	22	WEY7441L2007	SWITCH ASSEMBLY	1	
	23	WEY7441L6028	SCREW	2	(K3-6)
	24	WEY7441L2117	CONTROL PCB	1	
	25	WEY7460K3958	OPERATION PANEL	1	
	26	WEY7543K3187	PLATE HOOK	1	
	27	WEY7441L6487	NUT	1	(M4)
	28	WEY7441K6217	SCREW	1	(4*14)
	29	WEY7441K9038	TAPPING SCREW	8	(K3-20)
	-	WEY9633K7010	TOOL CASE	1	
	-	WEY7441K8109	OPERATING INSTRUCTIONS	1	