

Service Manual

Cordless Impact Wrench

Model No. EY75A8

Europe
Oceania

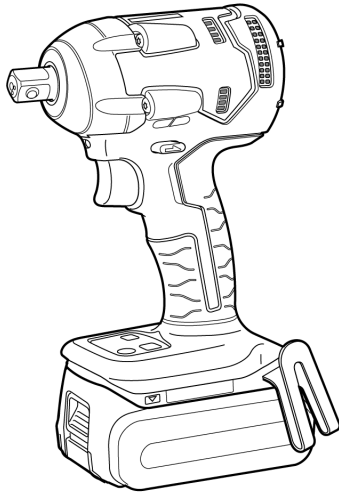

⚠ WARNING

This service information is designed for experienced repair technicians only and is not designed for use by the general public. It does not contain warnings or cautions to advise non-technical individuals of potential dangers in attempting to service a product. Products powered by electricity should be serviced or repaired only by experienced professional technicians. Any attempt to service or repair the product or products dealt with in this service information by anyone else could result in serious injury or death.

IMPORTANT SAFETY NOTICE

There are special components used in this equipment which are important for safety. These parts are marked by ⚠ in the Schematic Diagrams, Circuit Board Diagrams, Exploded Views and Replacement Parts List. It is essential that these critical parts should be replaced with manufacturer's specified parts to prevent shock, fire or other hazards. Do not modify the original design without permission of manufacturer.

TABLE OF CONTENTS

	PAGE	PAGE
1 Warning-----	2	
2 Specifications -----	2	
3 Troubleshooting Guide-----	3	
4 Disassembly and Assembly Instructions -----	6	
5 Exploded View and Replacement Parts List -----	10	

1 Warning

Caution:

- Pb free solder has a higher melting point than standard solder; Typically the melting point is 50 - 70 °F (30 - 40 °C) higher. Please use a soldering iron with temperature control and adjust it to 750 ± 20 °F (400 ± 10 °C). In case of using high temperature soldering iron, please be careful not to heat too long.
- Pb free solder will tend to splash when heated too high (about 1100°F / 600 °C).

2 Specifications

MAIN UNIT

Model No.		EY75A8	
Motor voltage		14.4 V DC	18 V DC
No load speed [min ⁻¹ (rpm)]	Soft mode	0 – 1000	
	Medium mode	0 – 1500	
	Hard mode	0 – 2300	0 – 2500
Maximum torque		260 N•m (26.5 kgf•m)	280 N•m (28.6 kgf•m)
Impact per minute [min ⁻¹ (ipm)]	Soft mode	0 – 1900	
	Medium mode	0 – 2900	
	Hard mode	0 – 3400	0 – 3600
Overall length		143 mm	
Weight	EY9L45	1.65 kg	—
With battery pack:	EY9L51	—	1.80 kg
	EY9L53	—	1.60 kg

MAXIMUM RECOMMENDED CAPACITIES

Model No.		EY75A8	
Bolt fastening	Standard bolt	M10 – M20	
	High tensile bolt	M10 – M16	

3 Troubleshooting Guide

3.1. Troubleshooting Guide

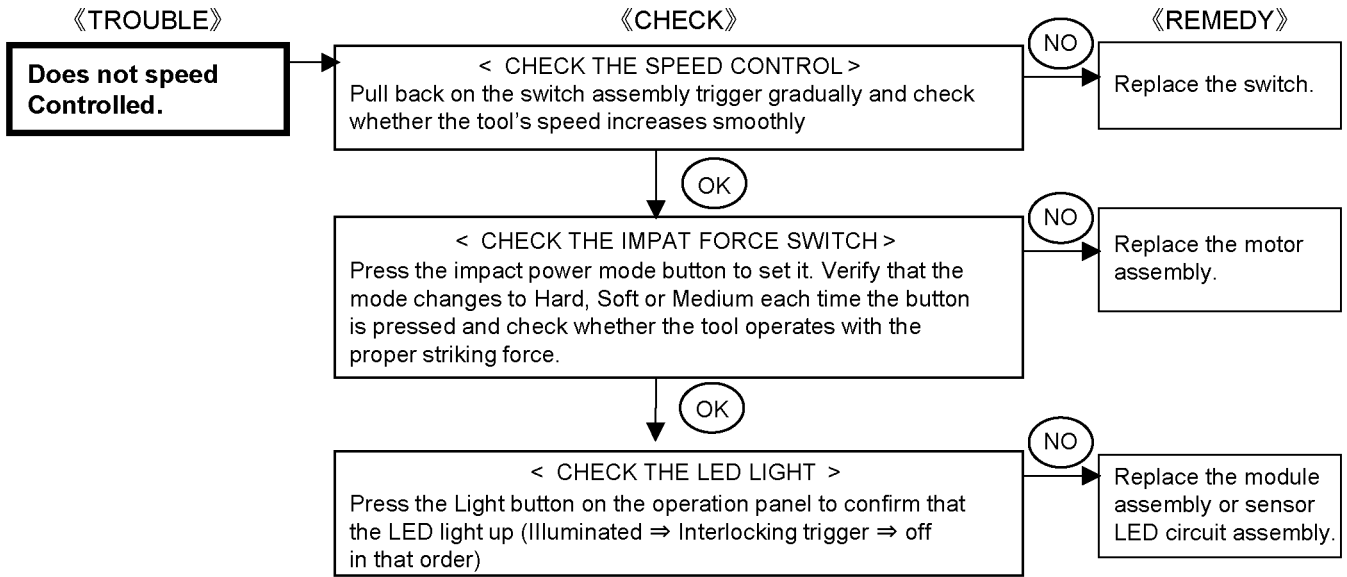
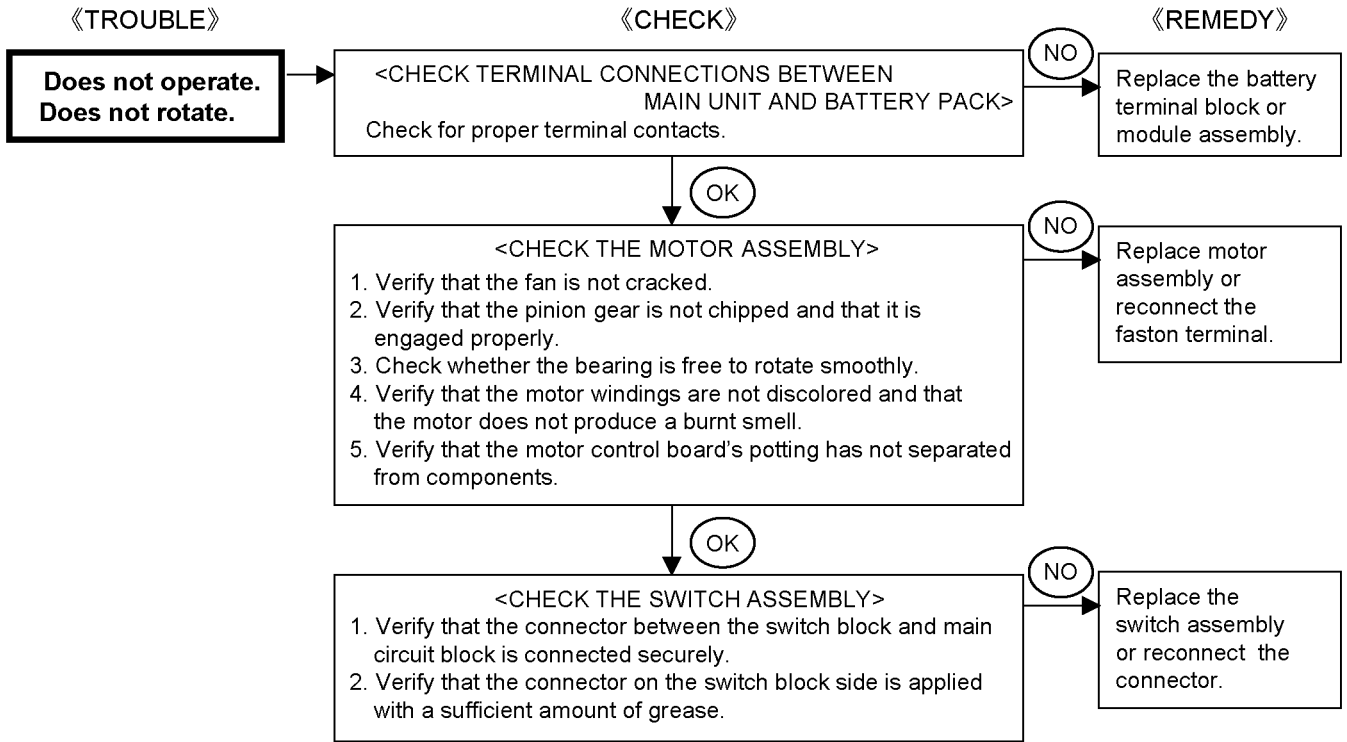

《TROUBLE》

The tool is not producing adequate impact force.

《CHECK》

《REMEDY》

*Before inspecting the anvil, inspect the battery pack and check the tool speed. Using a constant-voltage source, energize the tool with 18V/14.4V DC and pull back on the trigger with the F/R selector handle normal rotation mode. Check whether the tool speed is between 0 and 2,500 rpm

< CHECK THE ANVIL >
 Check the amount of wear on the anvil. Wear is within acceptable bounds if wear in the area of contact with the output shaft and hammer is limited to an area 1mm or less from the corner on surface A and an area 0.5mm or less from the corner on surface B. (See figure 1.)

NO

Replace the anvil.

Fig.1

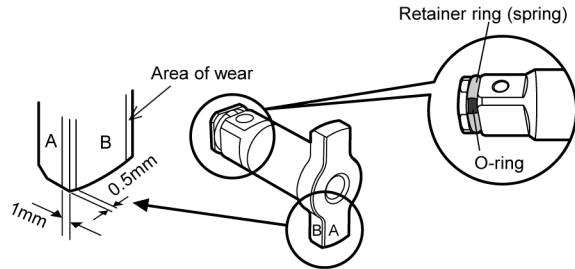

< CHECK THE DRIVING SHAFT ASSEMBLY >

- Check the amount of wear on the main hammer. Wear is within acceptable bounds if wear in the area of contact with the output shaft and hammer is limited to an area 2mm or less from the corner on surface C and an area 1mm or less from the corner on surface D. (See figure 2.)

Fig.2

- Check whether the hammer twists and rotates smoothly, as shown in the following figure. (See fig. 3)

Fig.3

Driving shaft assembly

NO

Replace the driving shaft assembly.

3.2. Trial Operation (after checking Troubleshooting Guide).

3.2.1. Assembly

- Confirm if there is no gap between housing A and B by pinching lead wires.
- There is no dust or deformation on battery terminals.
- Confirm all screws are tightened firmly.
- Confirm if there is no dirt when repairing.

3.2.2. Operation

- Check whether the tool operates properly in both the forward and reverse directions.
- Check whether the LED lights ON.

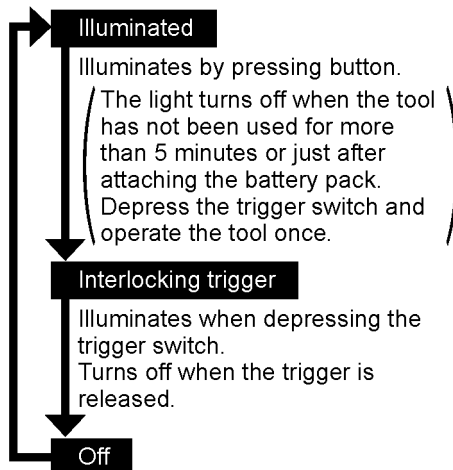

- Check whether the tool speed increases continuously as the trigger is gradually engaged.
- Check whether the tool speed is normal after repair and reassembly.
High mode: 0 to 2300 rpm at 14.4V, 0 to 2500 rpm at 18V.
Medium mode: 0 to 1500 rpm at 14.4V/18V.
Low mode: 0 to 1000 rpm at 14.4V/18V.
- Check whether the remaining battery power indicator lamp lights up or flashes when the Battery level button is pressed.

4 Disassembly and Assembly Instructions

* To reduce the risk of injury, always remove battery pack before removing/installing the tool.

* To assemble the tool, start with 4-4 and proceed to 4-1

4.1. How to remove the Housing.

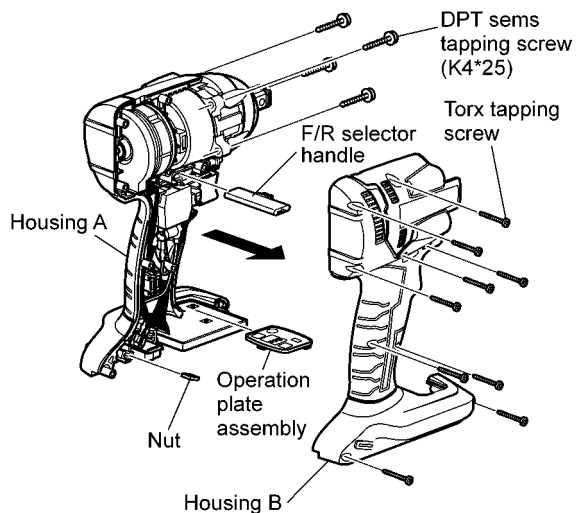

1. After removing the plate hook, remove 4 DPT sems tapping screws.
2. Remove 9 housing screws.
3. Then open the housing B.
4. Remove the interior parts.

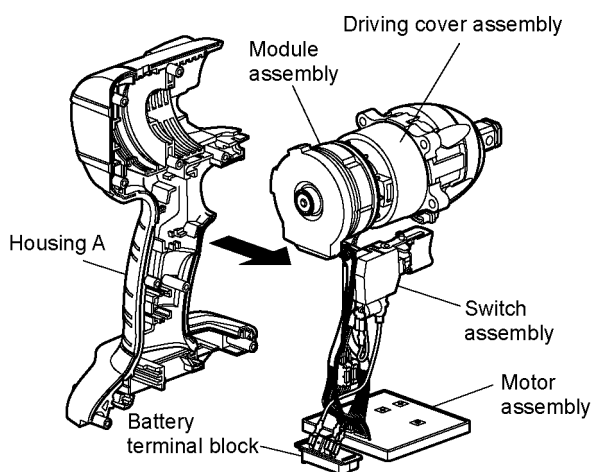

5. Remove the interior components from the housing A.

Note: (when assembling)

Route LED lead wires and motor lead wire between the ribs on housing A like the figure.

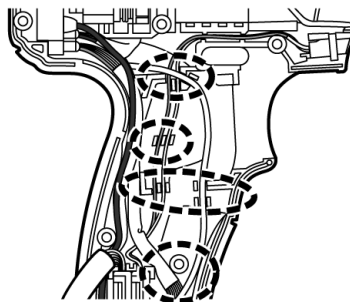

4.2. How to remove the Driving assembly.

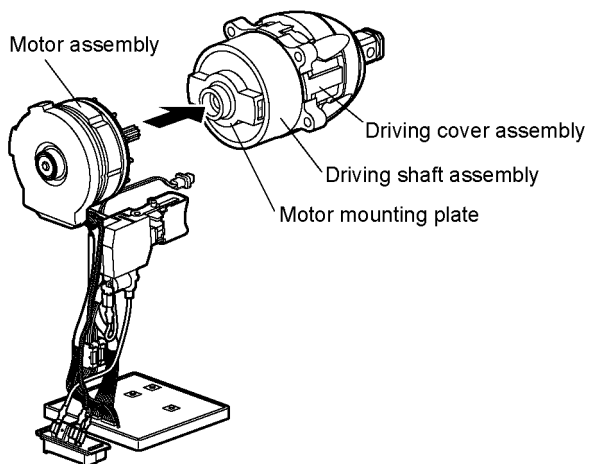

Hold the motor assembly, remove the driving cover assembly and associated parts together from the motor assembly.

4.3. How to remove the Driving cover assembly and Driving shaft assembly.

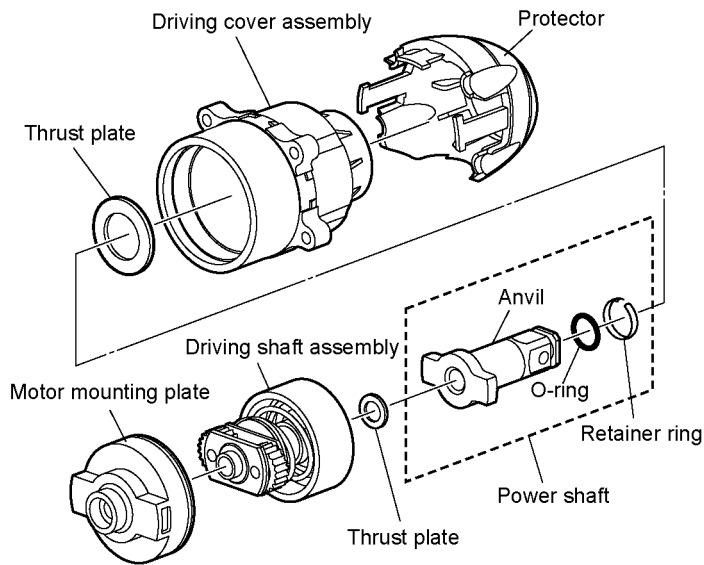

1. Remove the protector.
2. Remove the interior components from the driving cover assembly.

Note: (when assembling)

Apply grease (DOUBREX) to the indicated by the shaded area.

< Driving cover assembly >

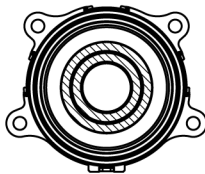

< Anvil >

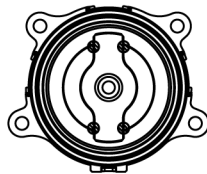

< Gear shaft >

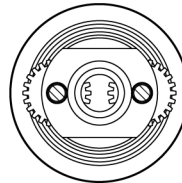

< Hammer >

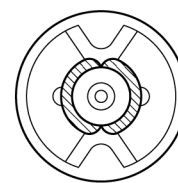

Apply grease (CALFOREX EP No. 2) to the indicated by the shaded area.

< Anvil >

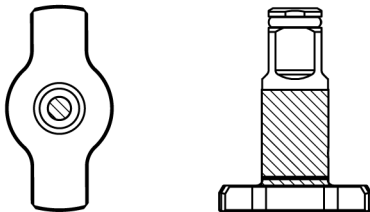

Apply grease (CALFOREX VS No. 2) to the indicated by the shaded area.

< Motor mounting plate >

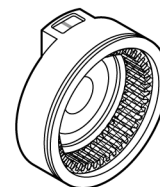

*Precautions when assembling the Motor mounting plate and Driving cover assembly.

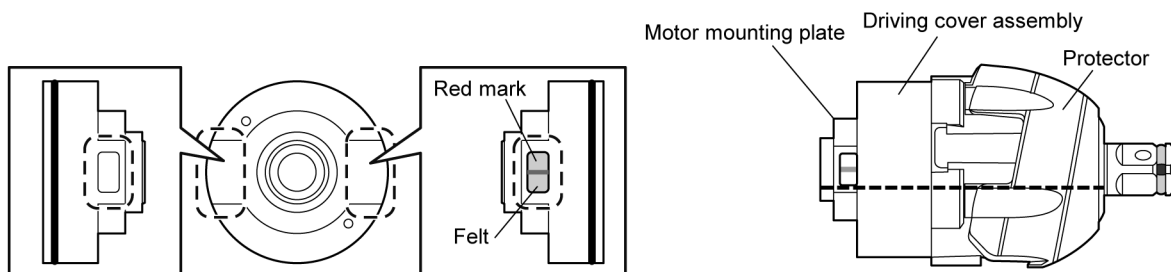

The motor mounting plate has its own direction for assembling.

Align the motor mounting plate with the notch on the protector as shown in the diagram.

4.4. How to remove the Switch assembly, LED harness assembly and Battery terminal.

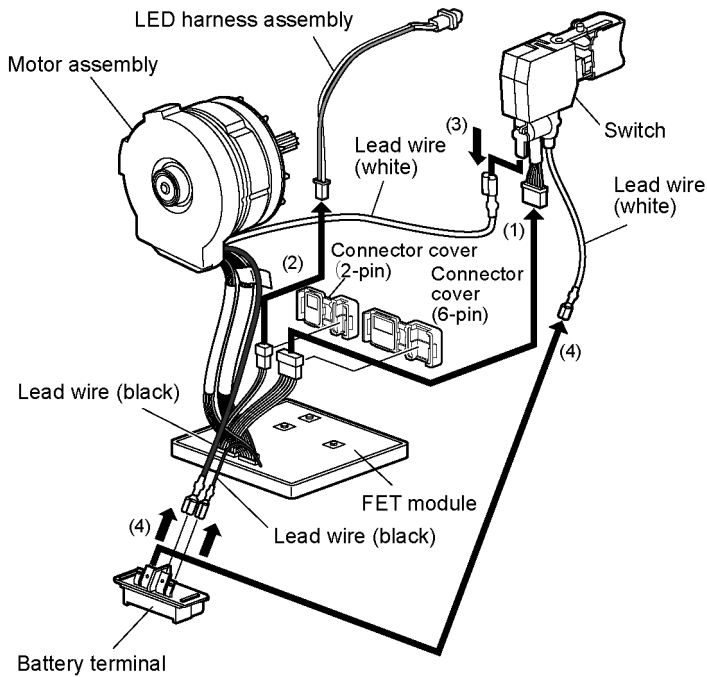

1. Remove the connector(6-pin/2-pin) covers.
2. Disconnect the connectors or lead wires in order to (1) to (4).

Note:

Exercise care not to bend the terminal fitting.

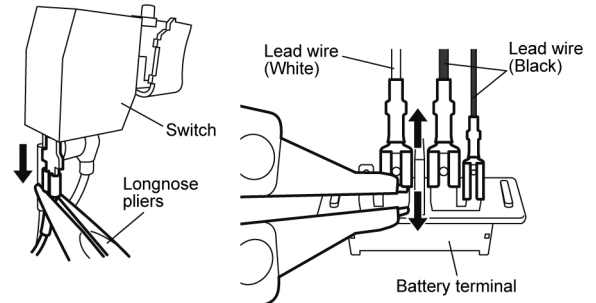

Note: (when assembling)

The connect cover cannot be reused after being repaired.

< How to attached the 2-pin connector >

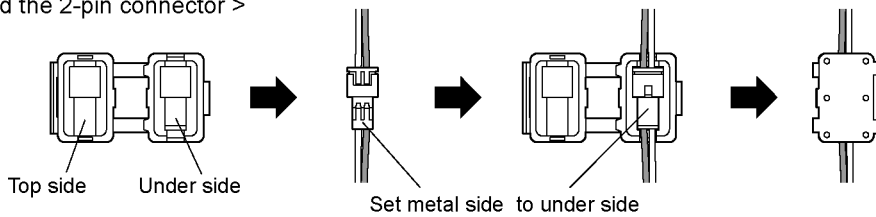

< How to attached the 6-pin connector >

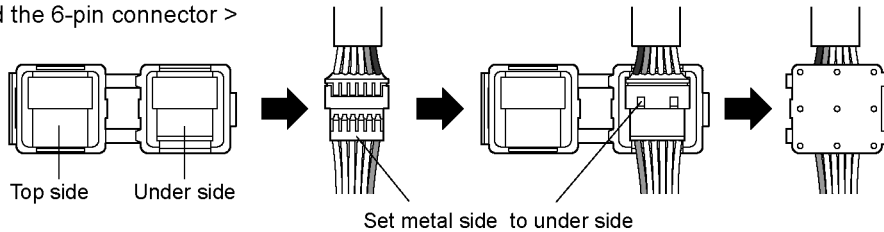

NOTE:(When attaching the connectors/switch).

Apply grease (Permalub) to the indicated by the shaded area.

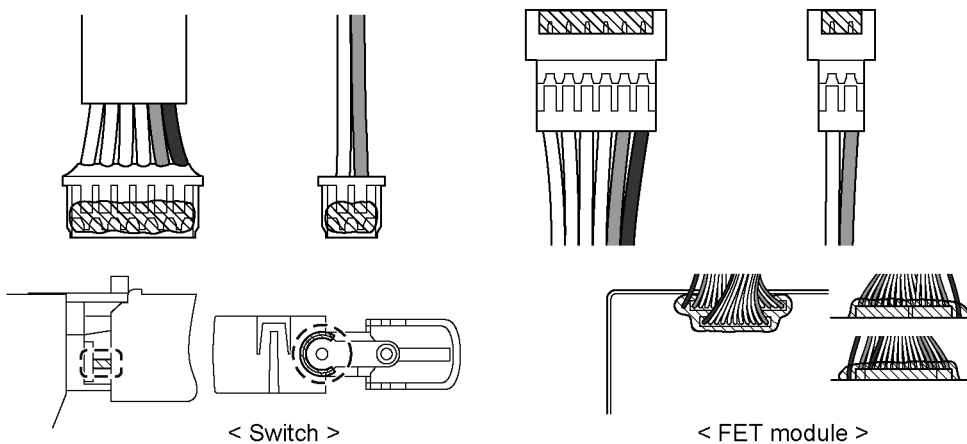

4.5. Wiring and Assembly Points.

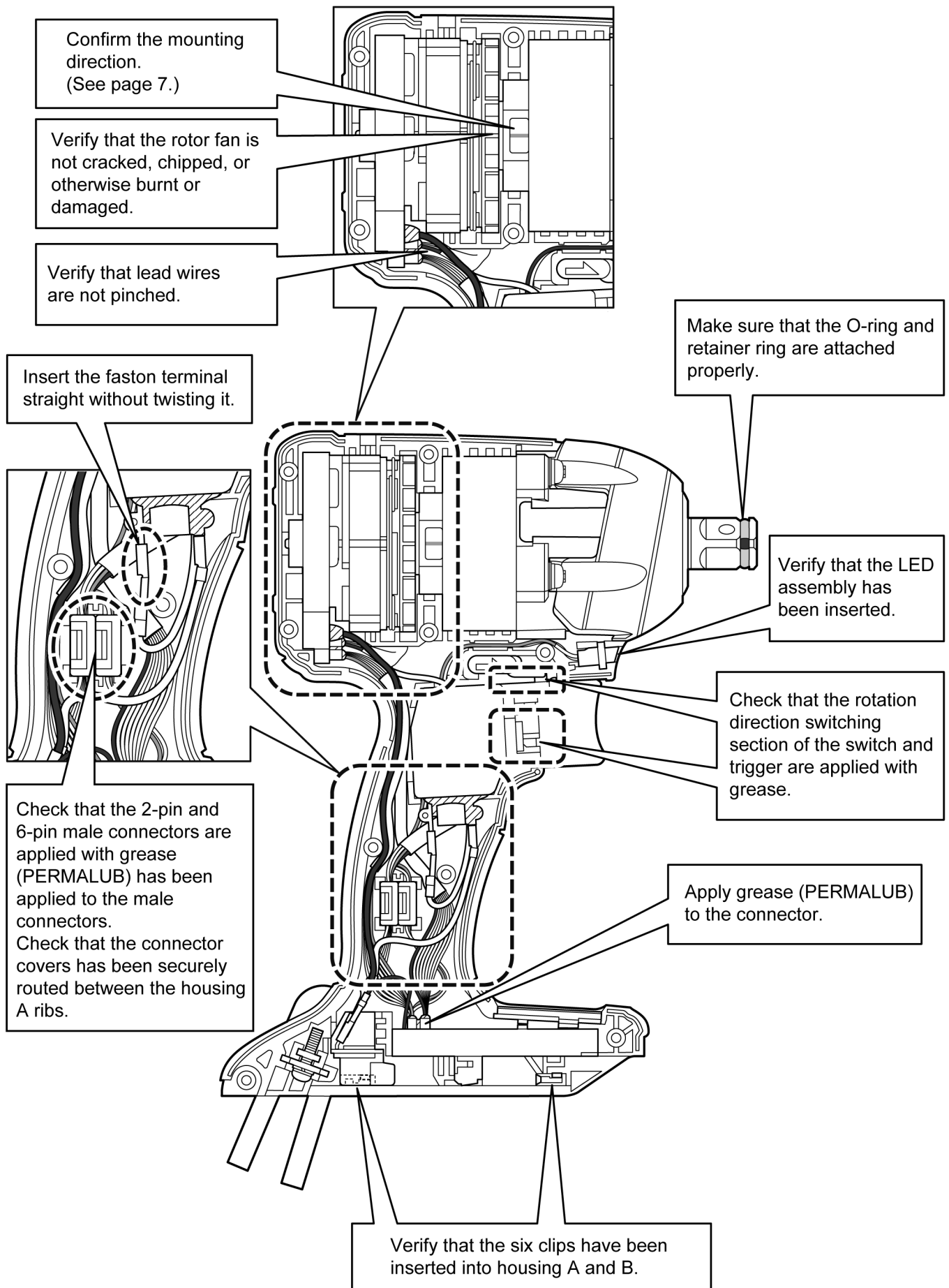

5 Exploded View and Replacement Parts List

Model No. : EY75A8 Exploded View

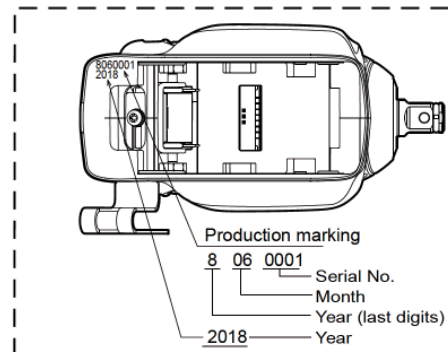
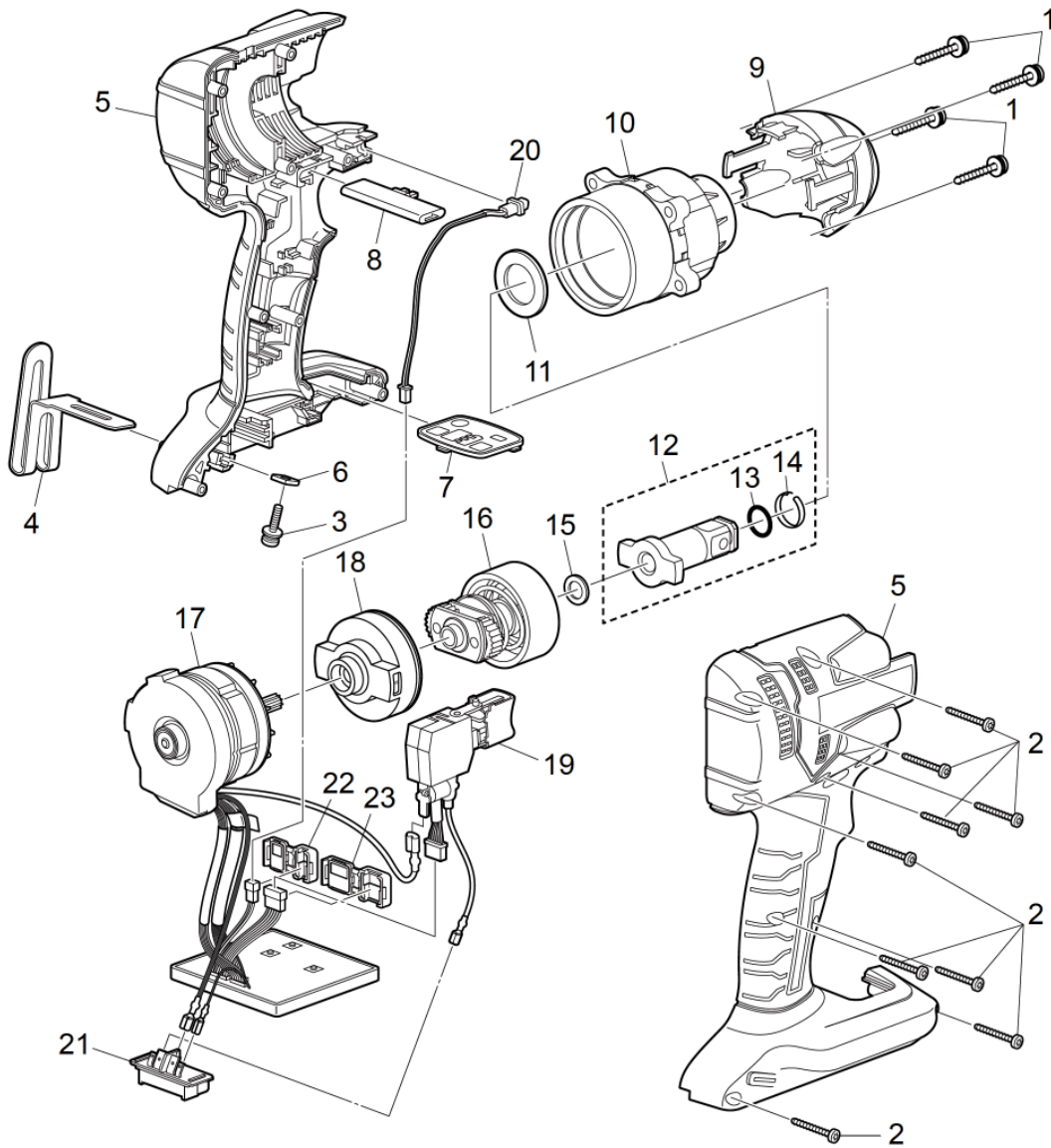

Model No. : EY75A8 Parts List

Change	Safety	Ref. No.	Part No.	Part Name & Description	Q'ty	Remarks
		1	WEY75A8K9108	DPT SEMS TAPPING SCREW	4	
		2	WEY6230K9216	TORX TAPPING SCREW	9	
		3	WEY7441K6217	SCREW	1	(K4*14)
		4	WEY7543K3187	PLATE HOOK	1	
		5	WEY75A8K3079	HOUSING AB SET	1	(for EUROPE)
		5	WEY75A8K3071	HOUSING AB SET	1	(for OCEANIA)
		6	WEY7441L6487	NUT	1	
		7	WEY75A8K3958	OPERATION PLATE	1	
		8	WEY75A7H3247	F/R SELECTOR HANDLE	1	
		9	WEY75A8S3107	PROTECTOR	1	
		10	WEY75A8S3747	DRIVING COVER ASSEMBLY	1	
		11	WEY75A8K0847	THRUST PLATE	1	
		12	WEY75A8S1128	ANVIL	1	
		13	WEY7552K0987	O-RING	1	
		14	WEY7552K0187	RETAINER RING	1	
		15	WEY75A7K0847	THRUST PLATE	1	
		16	WEY75A8S1157	DRIVING SHAFT ASSEMBLY	1	
		17	WEY75A8L4378	MOTOR ASSEMBLY	1	
		18	WEY75A8L0027	MOTOR MOUNTING PLATE ASSEMBLY	1	
		19	WEY75A8L2007	SWITCH ASSEMBLY	1	
		20	WEY75A8L2337	LED HARNESS ASSEMBLY	1	
		21	WEY75A7K2157	BATTERY TERMINAL ASSEMBLY	1	
		22	WEY75A8W3117	2-PIN CONNECTOR COVER	1	
		23	WEY75A8W3127	6-PIN CONNECTOR COVER	1	
		-	WEY75A7K8103	OPERATING INSTRUCTIONS	1	
		-	WEY003W8957	GREASE (PERMALUB)	1	
		-	WEY002X8977	GREASE (DOUBREX)	1	
		-	WEY004X8967	CALFOREX (EP No. 2)	1	
		-	WEY004X8977	CALFOREX (VS No. 2)	1	